

Chapter 1
ECD-V3

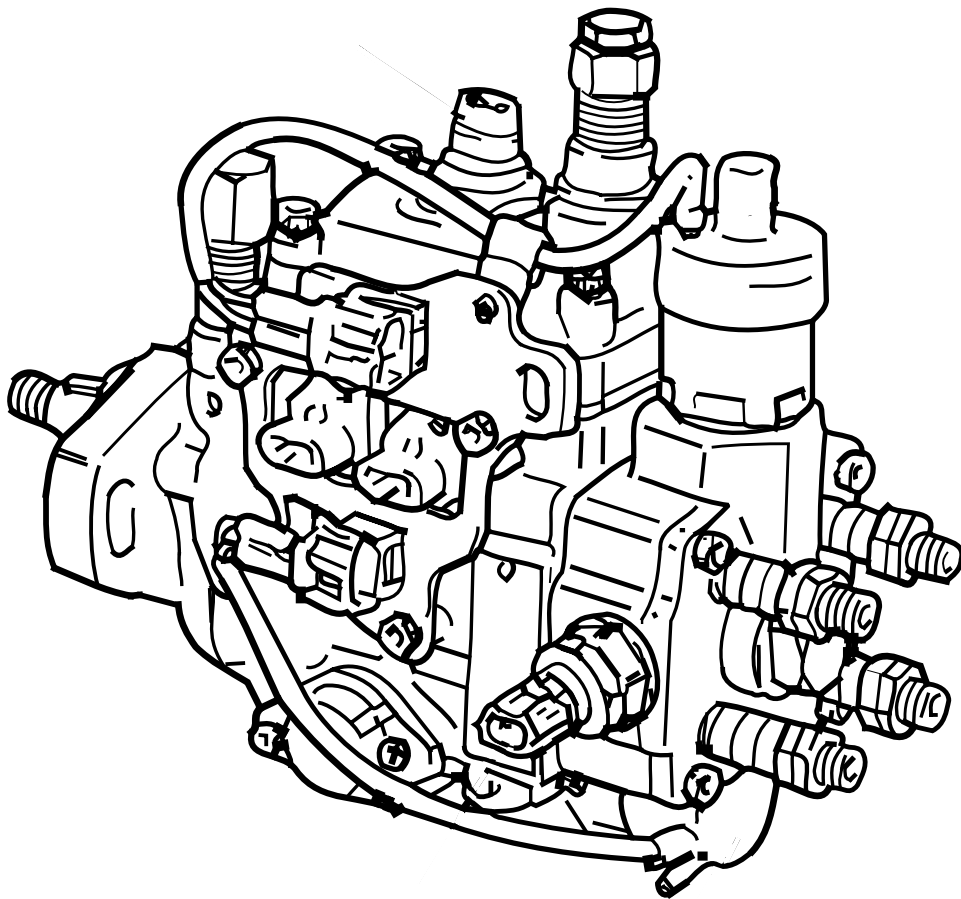

Chapter 1 - Table of Contents

1. Outline	17
2. System Composition	17
2-1. Construction of Injection Pump	18
2-2. System Components (on-vehicle layout example)	19
3. Fuel Pressure-Feed and Injection	19
4. Fuel Injection Volume Control	20
4-1. Outline of Injection Volume Control	20
4-2. System Components	21
4-3. Fuel Injection Volume Control	26
4-4. Relationship Between Vehicle (Engine) and Fuel Injection Volume Control	30
4-5. Determining the Final Injection Volume	31
4-6. Various Types of Injection Volume Corrections	31
4-7. Summary of Injection Volume Control (typical examples)	34
5. Fuel Injection Timing Control	36
5-1. Outline of Injection Timing Control	36
5-2. Components	36
5-3. Injection Timing Control	37
5-4. Determining the Final Injection Timing	40
5-5. Various Times of Timing Advance Corrections	40
5-6. Timing Control Valve (TCV) Actuation Method	42
5-7. Summary of Injection Timing Control (typical examples).....	43
6. Idle Speed Control	45
6-1. Outline	45
6-2. Idle Speed Control	45
7. Idle Speed Control	46
7-1. Function	46
7-2. Construction	46
7-3. Operation	47
8. EGR Control	53
8-1. Construction and Operation of Components	53
8-2. Determining the EGR Volume	54
8-3. EGR Correction Coefficient	54
9. Glow Plug Control	55
9-1. Glow Plug Indicator Illumination Time control	55
9-2. Glow Plug Relay Control	55
10. Other Controls (control types by engine model)	56
11. Diagnosis Function	57
12. Fail-Safe Function	57

1. Outline

In the electronically controlled fuel injection system of a distributor type pump, the computer detects the operating conditions of the engine in accordance with the signals received from various sensors (engine speed, acceleration, intake air pressure, water temperature sensors, etc.) in order to effect the following basic controls:

- a. Fuel injection volume control
- b. Fuel injection timing control
- c. Idle speed control
- d. Throttle control
- e. EGR control
- f. Glow plug control

In addition, the system provides the following auxiliary functions:

- g. Diagnosis function
- h. Fail-safe function

2. System Composition

The electronically controlled system of a distributor type pump can be broadly divided into the following three components: sensors, microcomputer (ECU), and actuators.

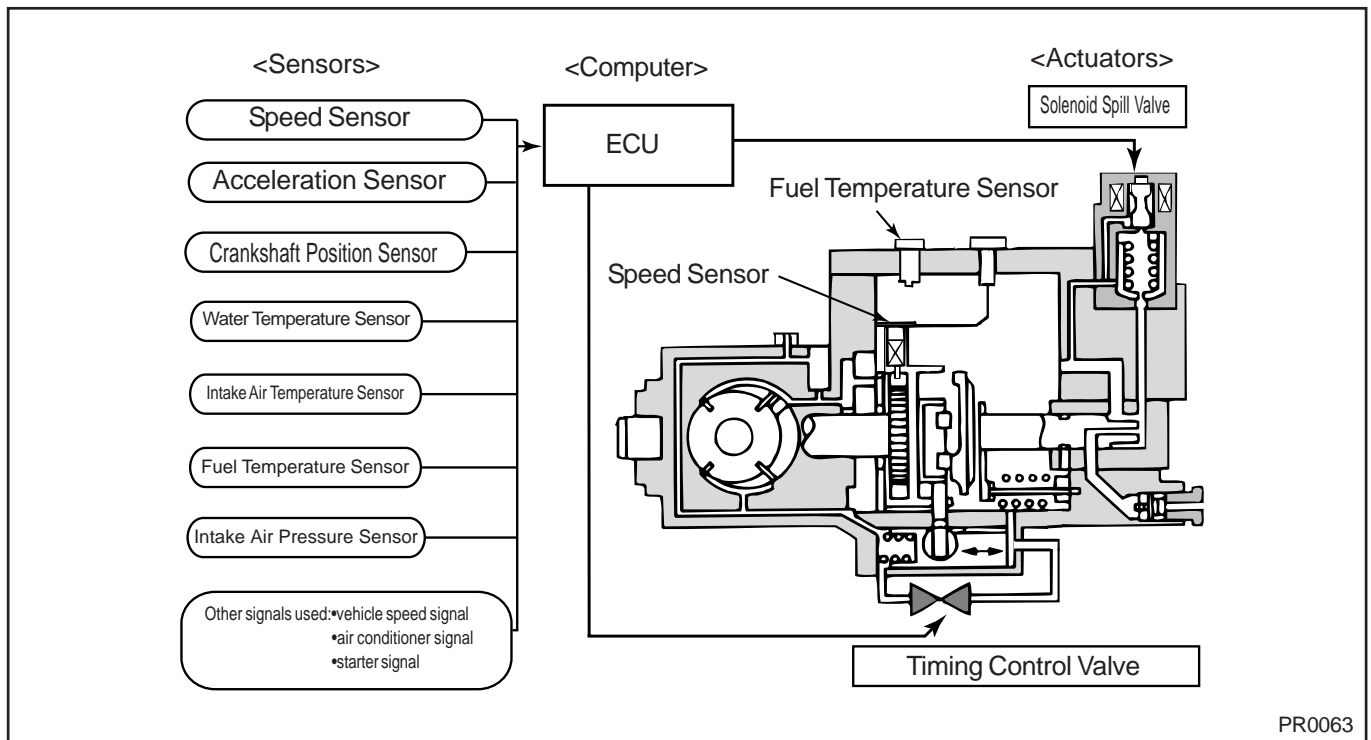

Sensors	Detect the conditions of the engine or the pump itself.
Actuators	Regulate the injection volume and injection timing in accordance with the signals received from the computer.
Computer	Calculates the injection volume and injection timing that are optimal for the engine operation in accordance with the signals from the sensors.

2-1. Construction of Injection Pump

The following electrical parts are attached to the electronically controlled distributor type pump:

a. Actuators

- Solenoid spill valve (SPV) to control the injection volume
- Timing control valve (TCV) to control the injection timing

b. Sensors

- Speed sensor
- Fuel temperature sensor

c. ROM (or correction resistors on the conventional type)

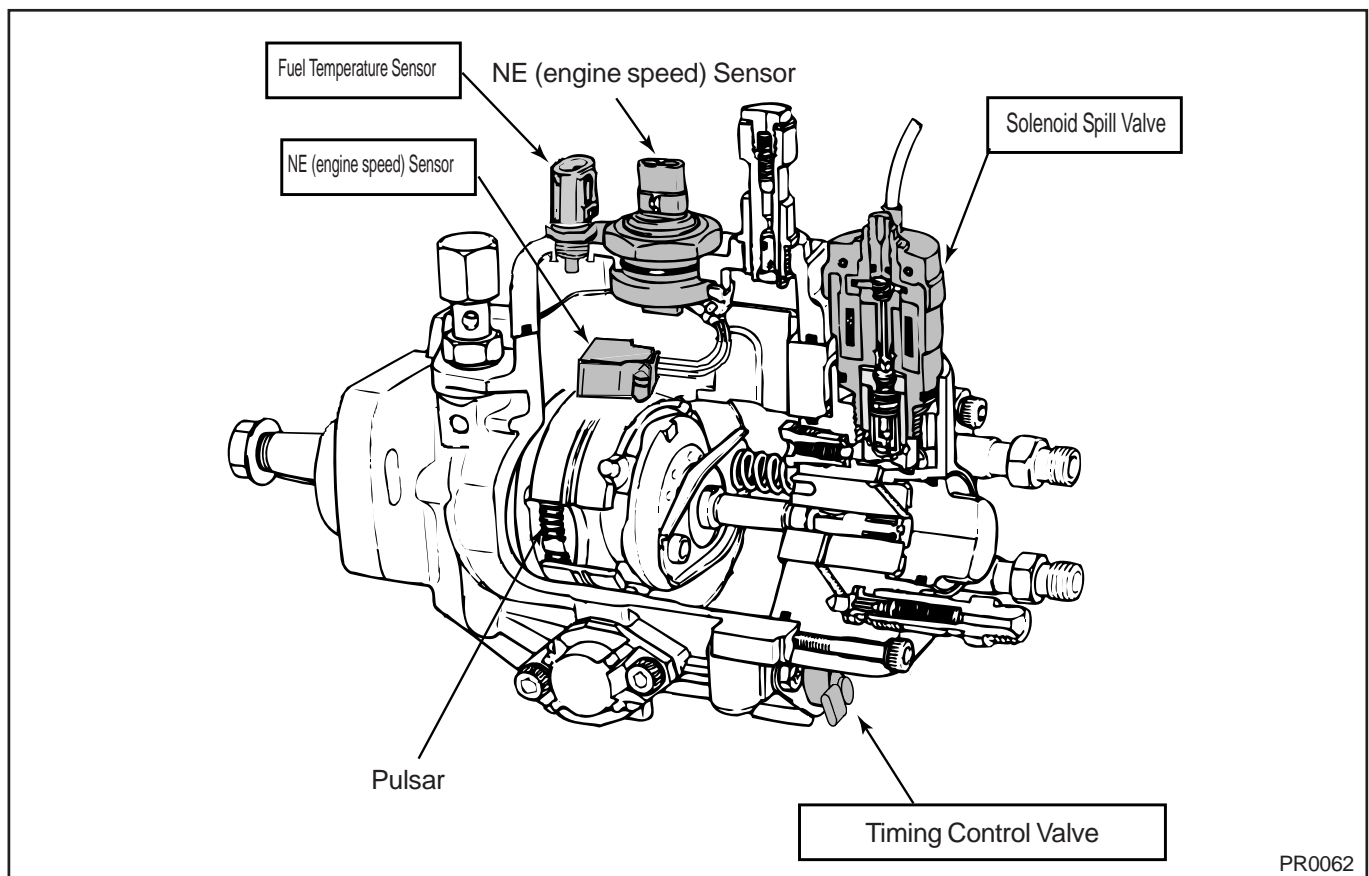
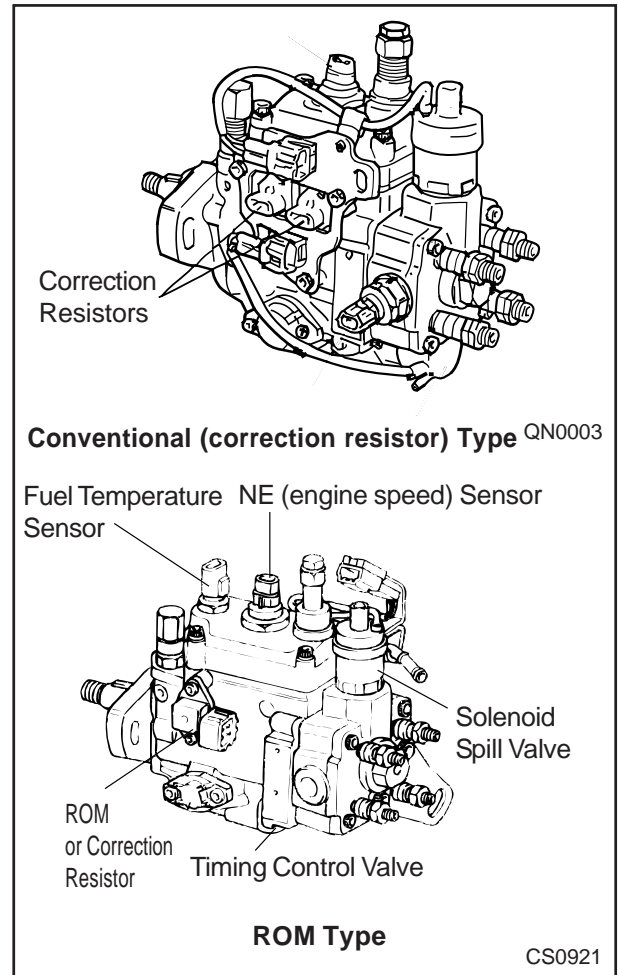

2-2. System Components (on-vehicle layout example)

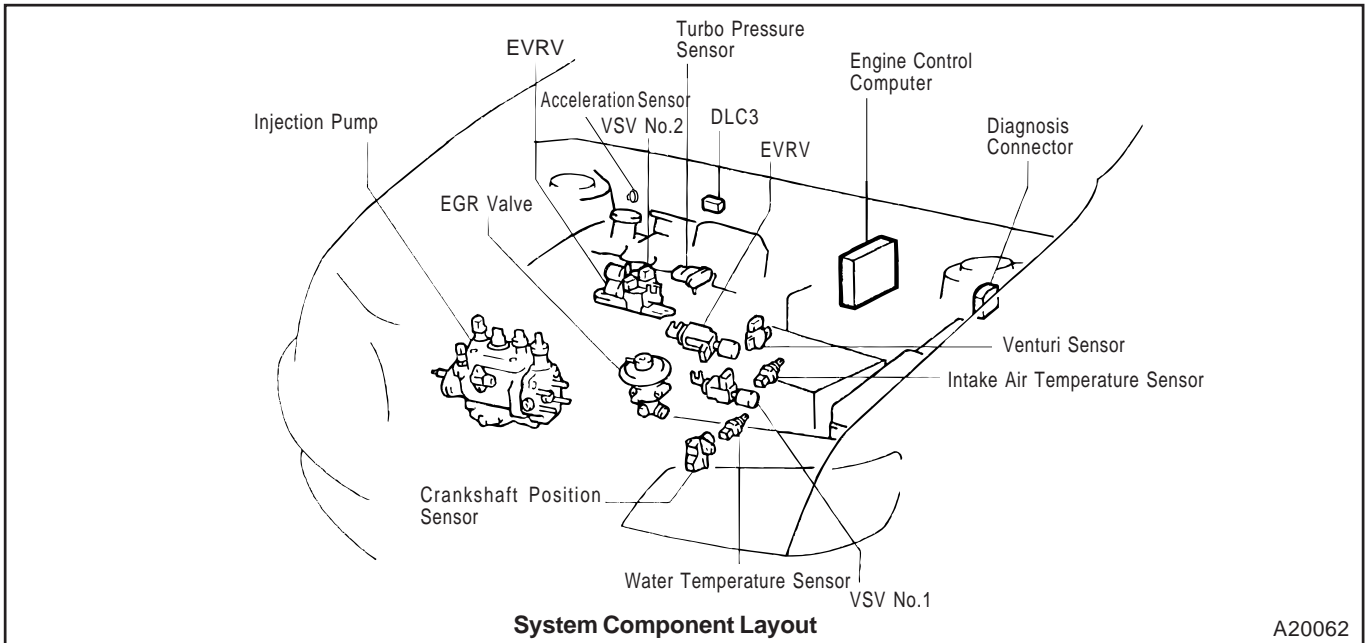

3. Fuel Pressure-Feed and Injection

The mechanisms for pressure-feeding and distributing fuel are basically the same as in the conventional mechanical pump, although there are some differences associated with the adoption of the solenoid spill valve.

The solenoid spill valve is provided in the passage that connects the pump chamber with the pressure chamber of the plunger, and it remains closed when the coil is energized. (See page 28 for details on the solenoid spill valve.)

(1) Suction

Fuel is drawn into the pressure chamber when the plunger descends.

- Suction port: open
- Distribution port: closed
- Solenoid spill valve: closed (energized)

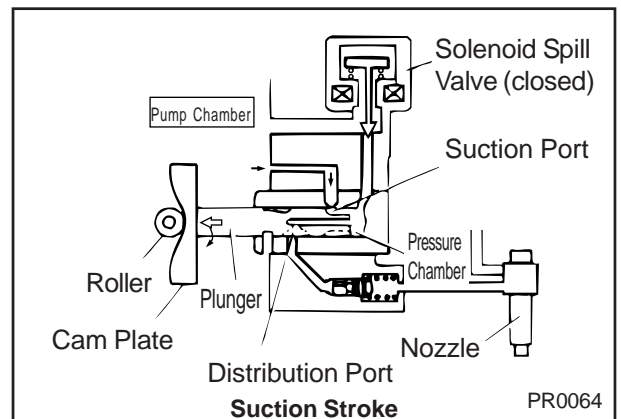

(2) Injection

The plunger ascends while rotating in order to pump fuel.

- Suction port: closed
- Distribution port: open
- Solenoid spill valve: closed (energized)

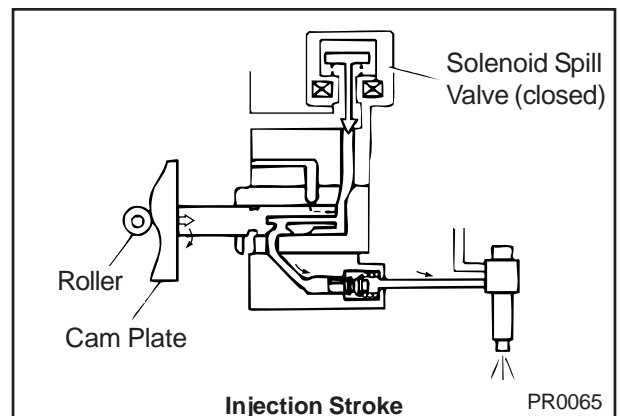

(3) End of Injection

When the solenoid spill valve is no longer energized, its valve opens. The highly pressurized fuel in the plunger is then pushed back into the pump chamber, the fuel pressure drops, and the pumping ends.

(4) Fuel Cutoff

When the fuel is cut off, the solenoid spill valve is not energized and its valve remains open. Therefore, fuel is not pumped even if the plunger ascends. There are also other systems that use a fuel cutoff valve for this purpose.

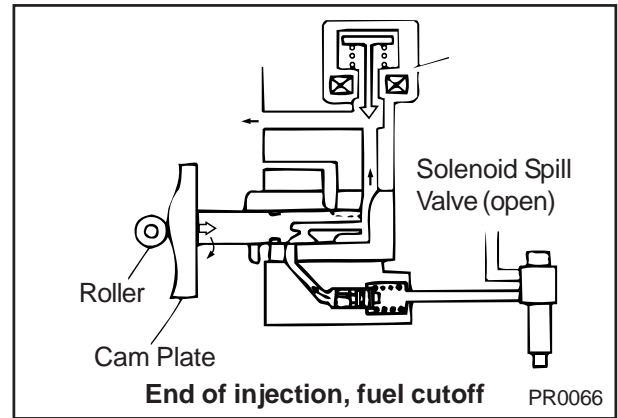

4. Fuel Injection Volume Control

4-1. Outline of Injection Volume Control

The computer has in its memory the basic injection volume data that was calculated based on factors such as the engine speed or the acceleration opening. Corrections based on factors such as the intake air pressure, coolant temperature, or intake air temperature are added to the basic injection volume. Then, the computer sends signals to the solenoid spill valve in the pump in order to control an optimal fuel injection volume. The special characteristic of the ECD-V3 (ROM) pump is the phase correction that is made based on the ROM that is mounted to the pump body.

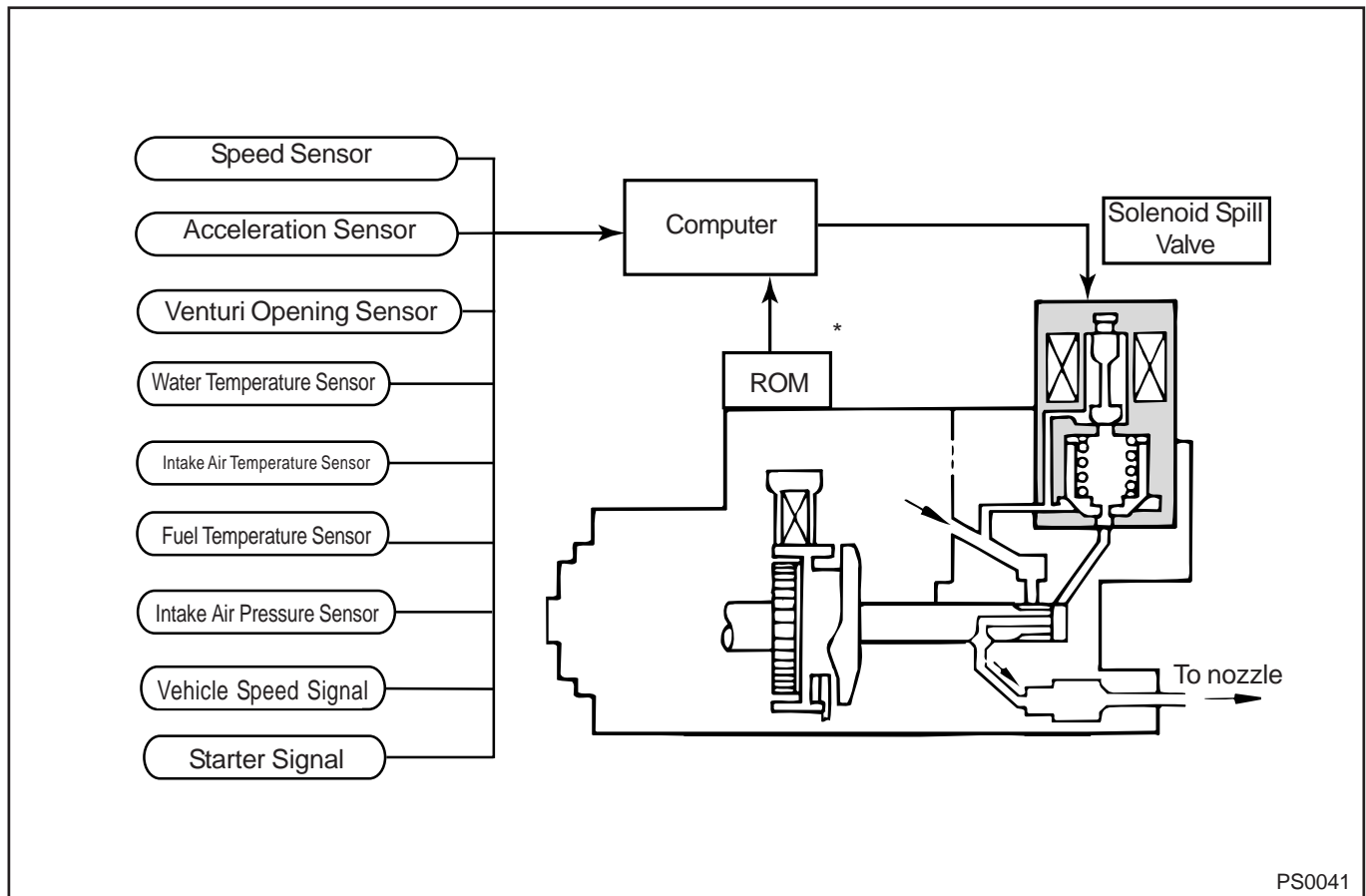

*Or, correction resistors (θ resistors) on conventional type

4-2. System Components

(1) Intake Air Pressure Sensor

This sensor detects the intake air pressure by absolute pressure* and sends it to the computer in the form of an intake air pressure signal.

It is a semiconductor pressure sensor that utilizes the property of the (silicon) crystal that is sealed inside the sensor, whose electrical resistance changes when pressure is applied to the crystal.

*Absolute pressure: a pressure at 0 vacuum

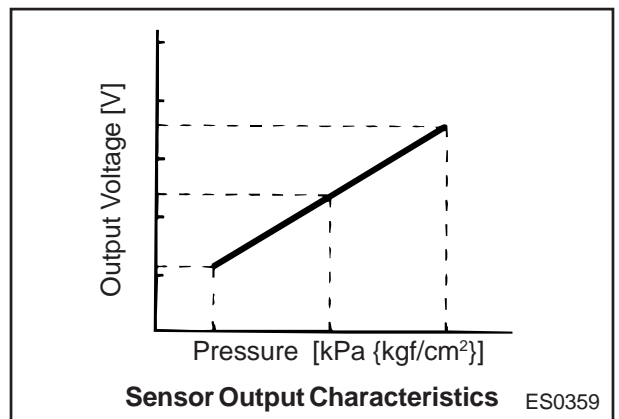
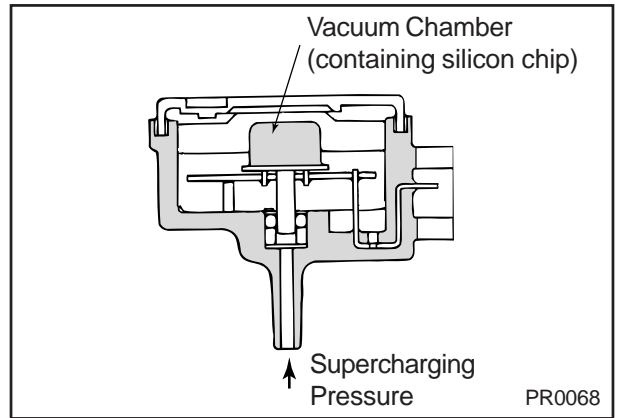

(2) Speed Sensor

The speed sensor is mounted so as to face the teeth of the pulsar (gear), which is pressed onto the pump drive shaft. The sensor contains a magnet and a coil, and when the pulsar rotates, the magnetic flux that passes the coil increases and decreases, causing an alternate current voltage to be generated in the coil. The computer counts the number of pulses to detect the engine speed. The pulsar has 52 teeth, with 3 teeth missing at 4 locations. Thus, the pulsar rotation angle is detected every 11.25°CA.

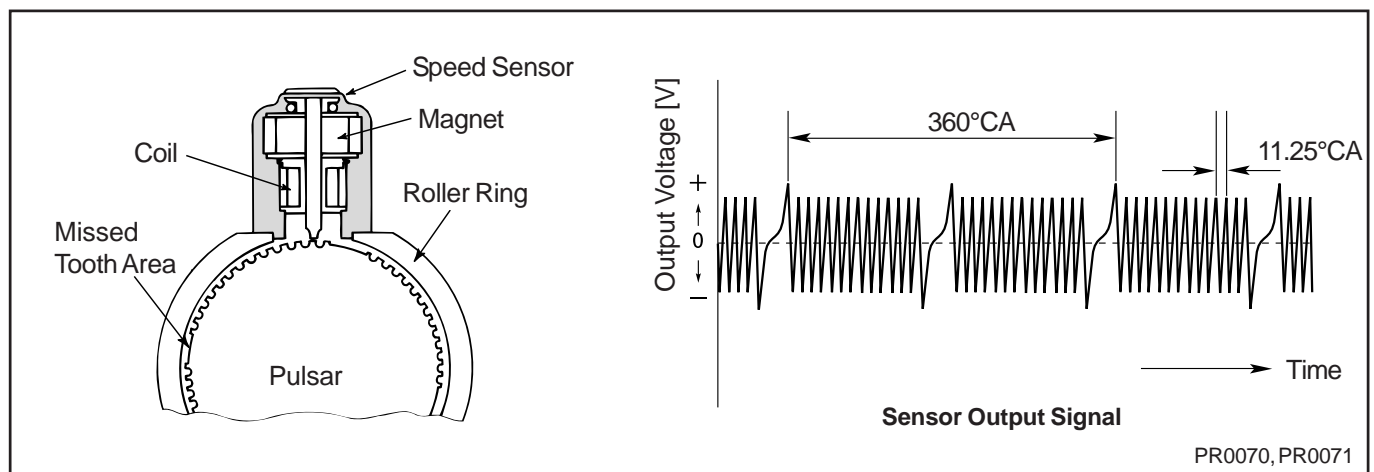

(3) Acceleration Sensor

The sensor for detecting the acceleration opening of the conventional ECD-V3 pump was mounted on the venturi. However, some of the ECD-V3 (ROM) pumps detect the opening at the accelerator pedal. With either type, the voltage at the output terminal changes in accordance with the acceleration opening, and the idle condition is detected by the ON/OFF signal from the idle switch.

This is a dual system that enhances control precision and consists of the following:

- a. Idle switch and acceleration fully closed switch
- b. VA and VAS.

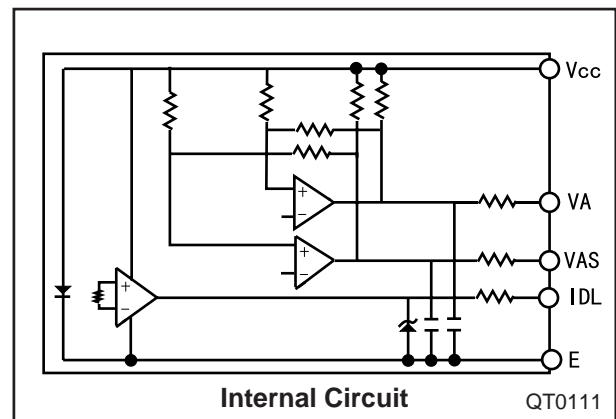
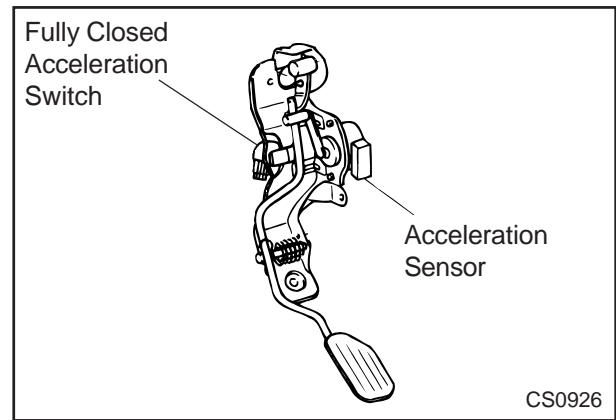

(4) Venturi Opening Sensor (or throttle position sensor)

This sensor is mounted to the conventional venturi or the vacuum type independent venturi to detect the valve opening that is necessary for controlling the throttle.

On some types of engines, the throttle control is effected by the signals from the acceleration sensor, instead of the venturi opening sensor.

(See pages 49 and 50 for details on the throttle control.)

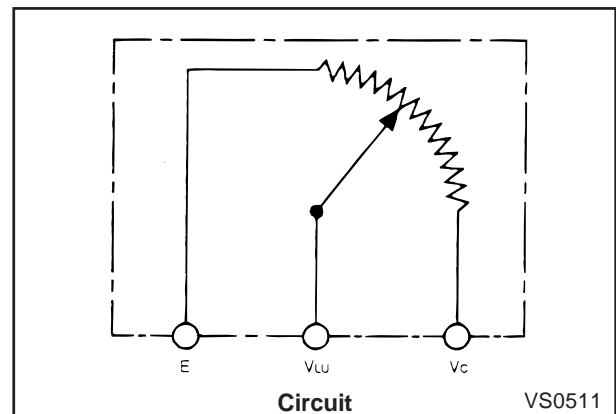
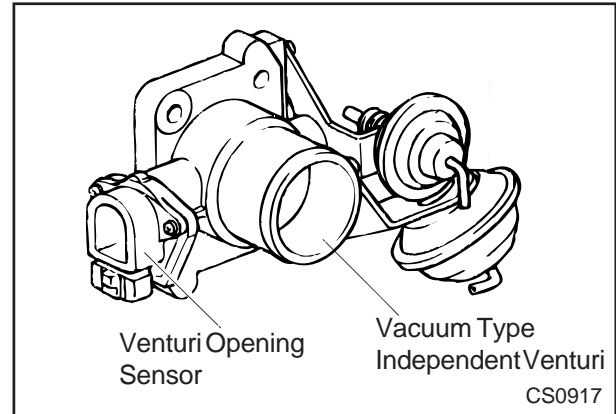

(5) Water Temperature Sensor

This sensor, which detects the coolant temperature, contains a thermistor. The thermistor is a type of semiconductor whose resistance changes significantly according to the temperature. Thus, the coolant temperature can be detected by the changes in the resistance.

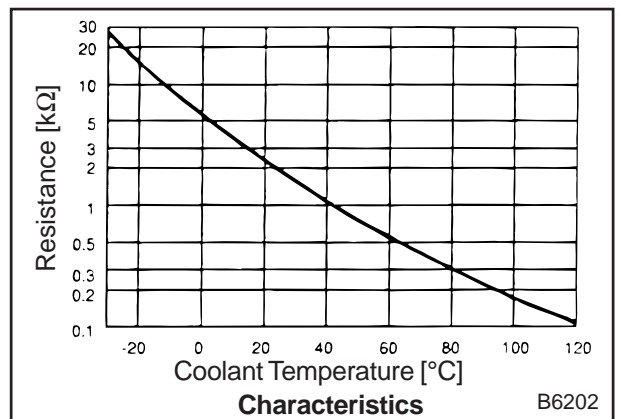
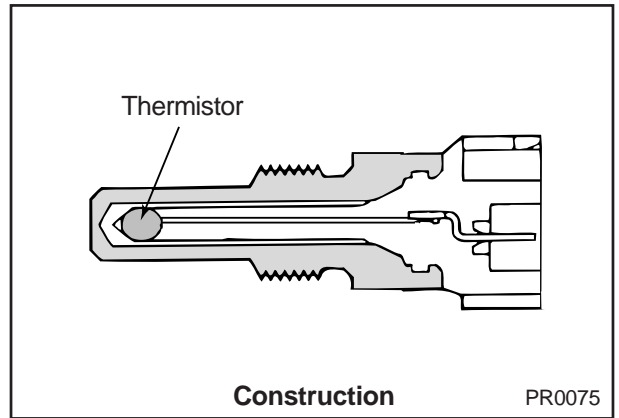

(6) Intake Air Temperature Sensor

This sensor contains a thermistor with the same type of characteristics as the water temperature sensor. It is mounted on the intake manifold of the engine to detect the temperature of the intake air.

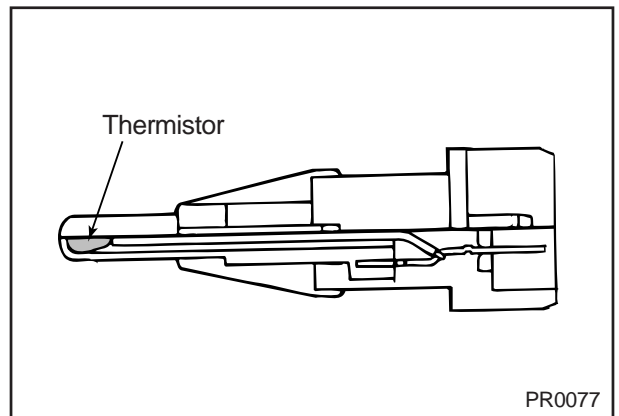

(7) Fuel Temperature Sensor

This sensor contains a thermistor with the same type of characteristics as the water temperature sensor. It is mounted on the pump to detect the temperature of the fuel.

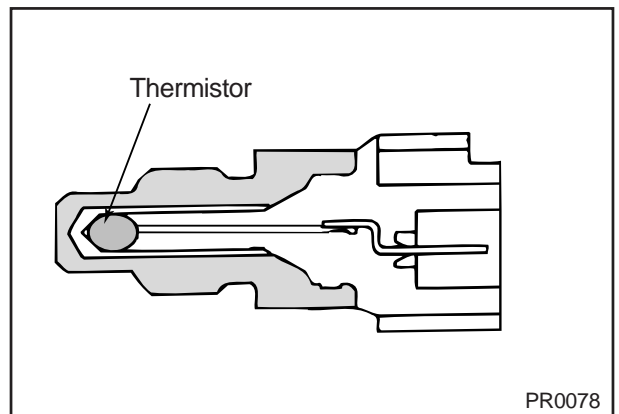

(8) Solenoid Spill Valve (SPV)

The solenoid spill valve directly controls the injection volume. It is a pilot type solenoid valve that provides high pressure resistance and high response. It contains two systems, the main valve, and pilot valve systems.

When the solenoid spill valve opens, the high pressure fuel in the plunger returns to the pump chamber, causing the injection of fuel to end.

In addition to the conventional type of solenoid spill valve, there is also a direct-acting type that has been developed for higher spill performance (the ability of returning the high pressure in the plunger back to the pump chamber) and higher response.

▼ Operation

Coil current ON: valve closed

Coil current OFF: valve open

* See page 30 for details on the solenoid spill valve.

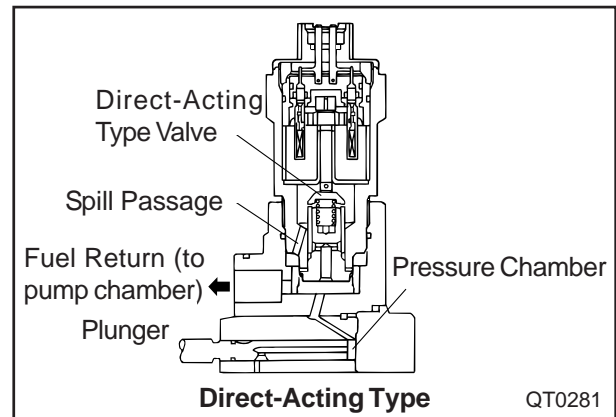
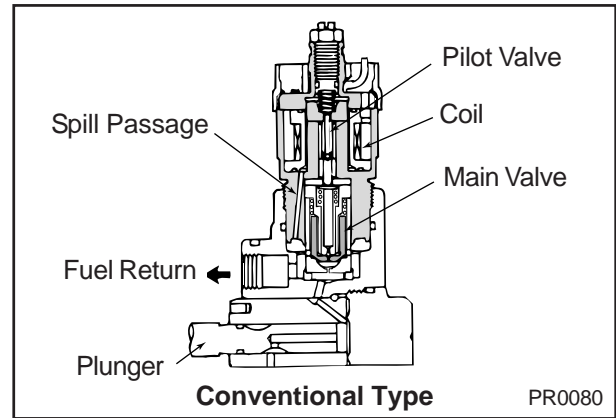

(9) Correction Resistors (θ , τ) or ROM

The resistors, which are located on the side of the injection pump body, apply a correction to the final-stage injection volume value that is calculated by the computer. The characteristic of the correction resistor is that each must be selected according to its unique resistance value, while the ROM provides storage for the correction data and the data can be easily rewritten.

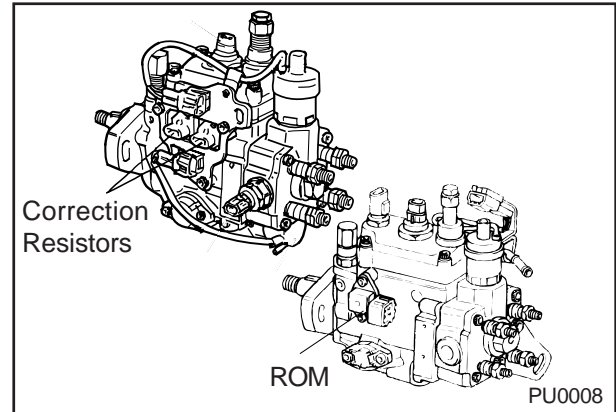

(10) Computer (ECU)

The computer determines the injection volume in accordance with the acceleration opening, engine speed, and the signals from the sensors.

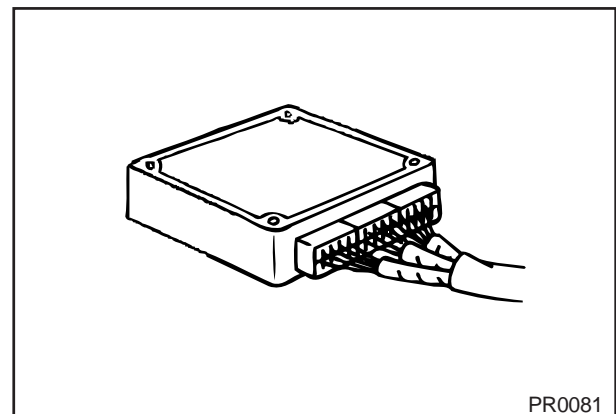

■ System Composition of Conventional ECD-V3

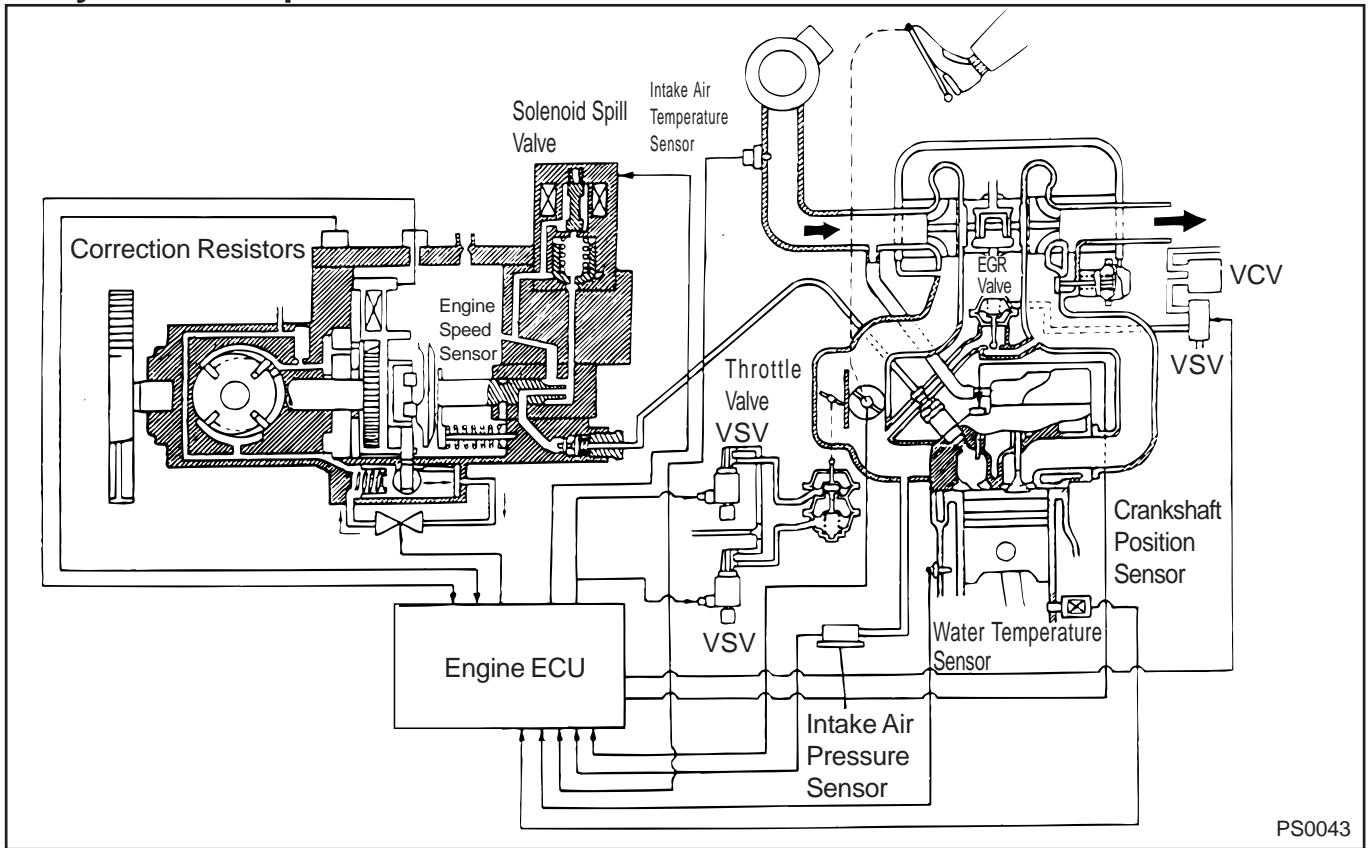

■ System Composition of ECD-V3 (ROM) [Example on 3C-TE engine]

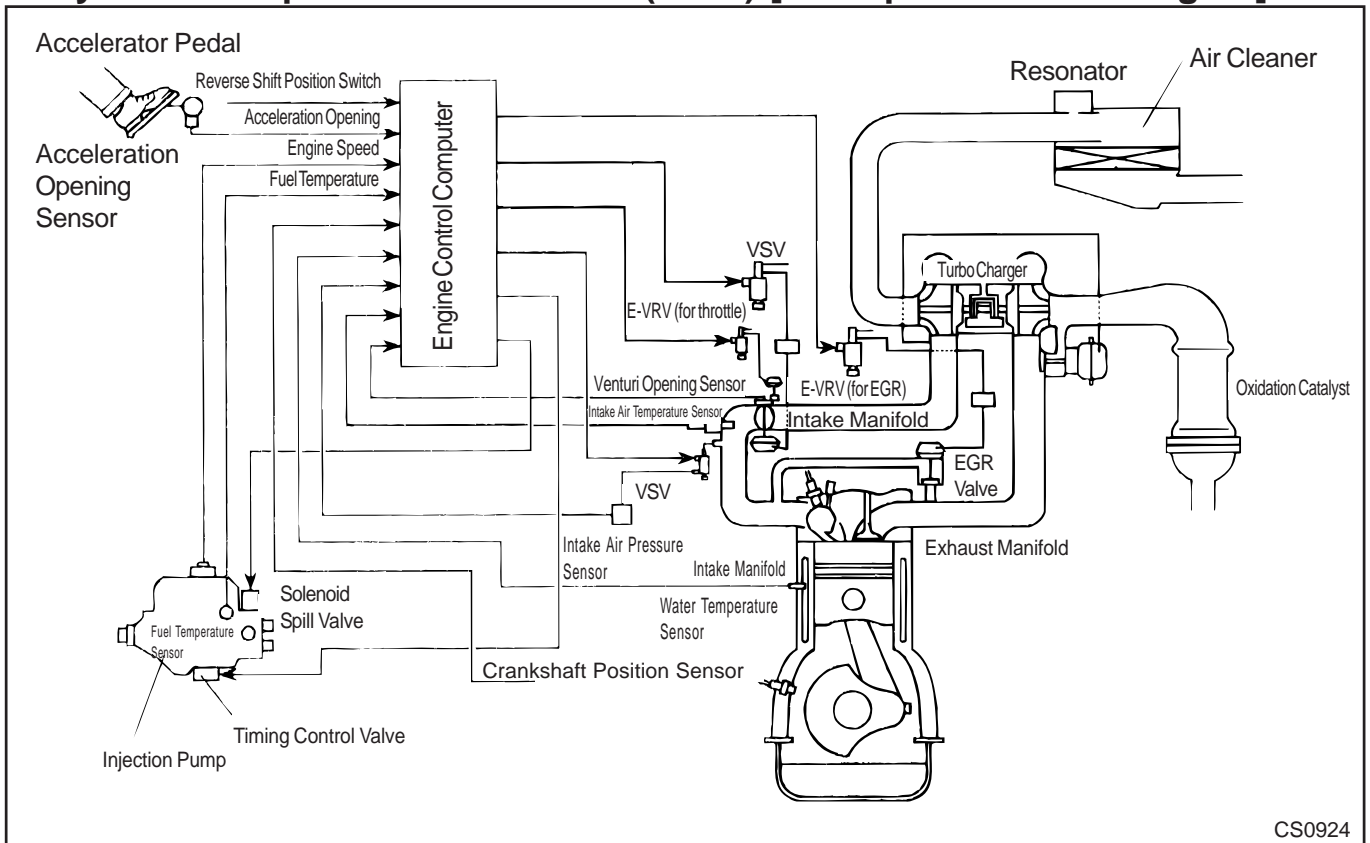

4-3. Fuel Injection Volume Control

(1) Fuel Injection Volume Control Method

The start of fuel injection is determined by the protruded surface of the cam plate, as in the past. Therefore, the timing of the end of injection must be controlled in order to regulate the volume of fuel injection. In other words, the end of injection occurs at the time the solenoid spill valve opens, allowing the high pressure fuel to spill into the pump chamber.

A speed sensor is used for determining the timing in which the solenoid spill valve opens, and the cam angle in proportion to the cam lift is detected in order to control the opening timing.

The diagram on the right shows the relationship between the timing in which the cam lift and the solenoid spill valve open and the injection volume.

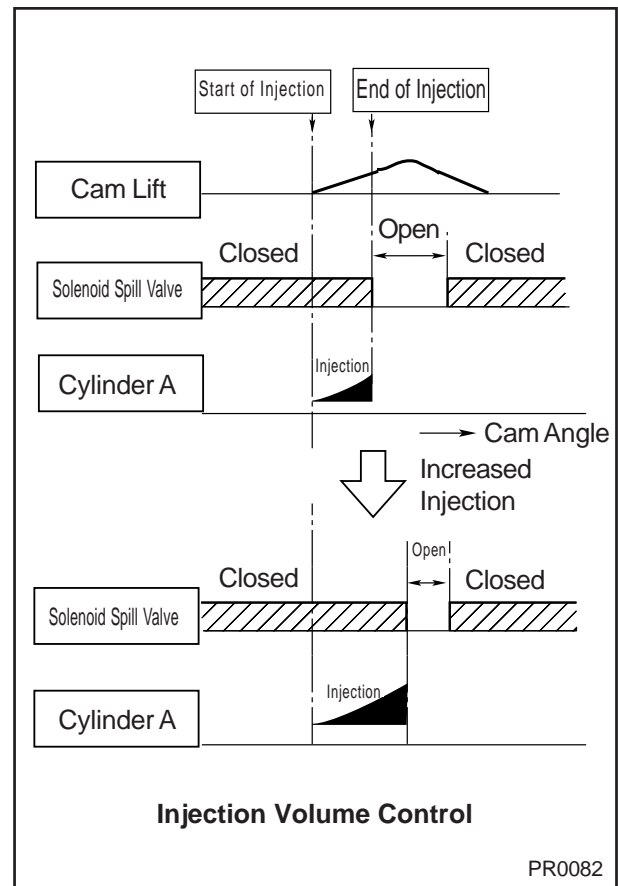
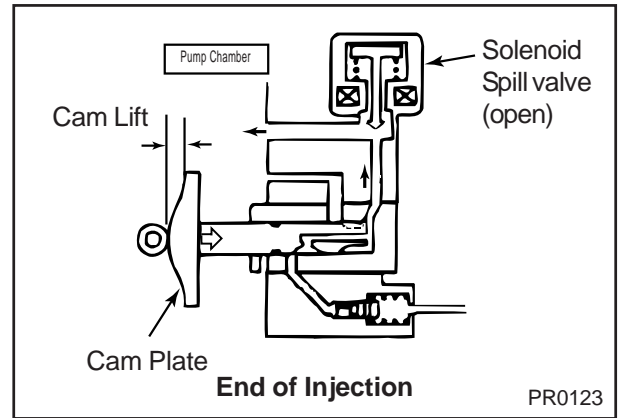

(2) Injection Volume Calculation

The computer calculates the injection volume that is optimal for the operating condition of the engine. To do so, it performs the following two calculations:

a. Basic Injection Volume

The injection volume that is theoretically necessary is calculated based on the acceleration opening and the engine speed.

b. Maximum Injection Volume

Corrections based on the intake air pressure, air temperature, and fuel temperature are added to the injection volume that is determined by the engine speed, in order to calculate the maximum injection volume while the engine is running.

The final injection volume is determined by selecting the lesser of the two injection volumes given in a. and b. above.

[Reference: Fuel Injection Volume Control Method]

The fuel injection volume must be regulated by controlling the timing of the end of injection, which is the timing in which the solenoid spill valve opens.

■ Solenoid Spill Valve Opening Timing

A speed sensor is used for determining the timing in which the solenoid spill valve opens, and the cam angle in proportion to the cam lift is detected.

Therefore,

- The cam lift is determined by the rotation angle of the cam plate. The cam plate rotates in unison with the gear that faces the speed sensor.
- Thus, the rotation angle of the cam plate can be detected by the rotation angle of the gear, which is the output of the speed sensor (that is output every 11.25°CA).
- The computer uses the signals from the speed sensor to determine the solenoid spill valve opening timing (end of injection) based on the number of teeth from the missed tooth area of the gear and on the length of time.

Note: The actual timing of the end of injection is determined by adding the corrections based on the engine speed, acceleration opening, and the signals from various sensors.

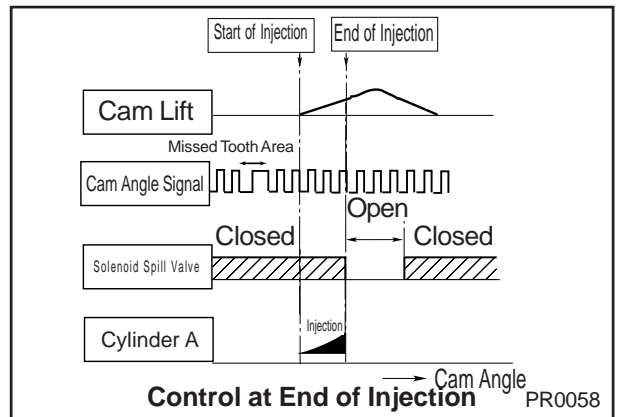
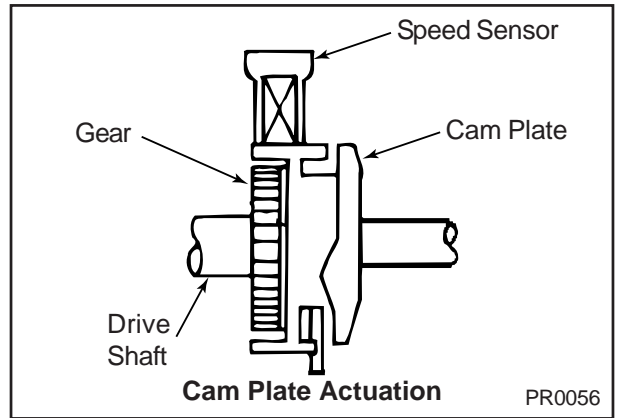

Example: 3C-TE Engine

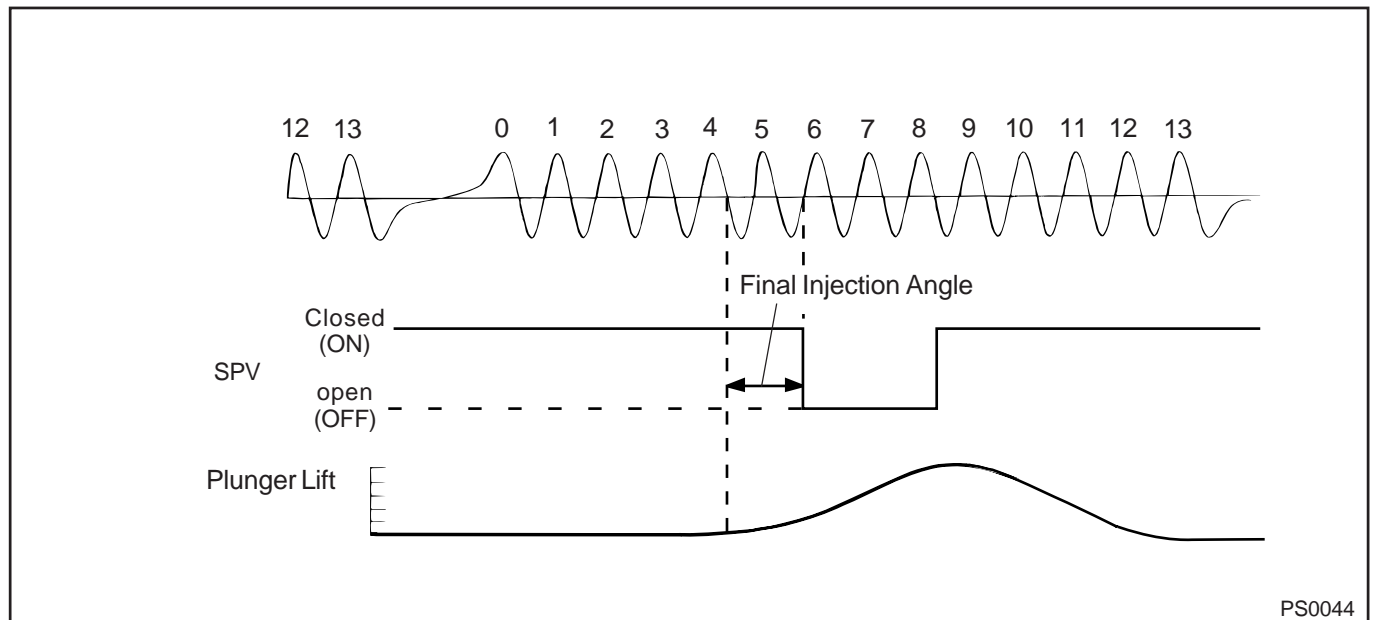

[Reference: Construction and Operation of Solenoid Spill Valve (conventional type)]

The solenoid spill valve, which consists of two systems, the main valve and pilot valve systems, has the functions given below.

Note: The diagram shows a basic construction.

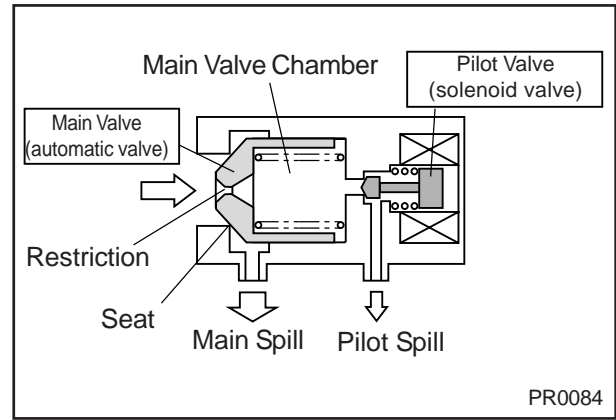

Function

	Flow Volume	Type	Function
Main Valve	Large	Automatic Valve (hydraulic type)	Spills the high pressure fuel in the plunger chamber to end injection.
Pilot Valve	Small	Solenoid Valve	Creates a hydraulic pressure difference that prompts the operation of the main valve.

Operation

(1) Pressure-Feeding and Injection

The high pressure fuel in the plunger chamber passes through the restrictor to fill the main valve. At this time, the fuel is injected from the nozzle. In this state, side B of the right and left areas of the main valve that receive pressure is larger than side A (in the diagram below), and the main valve remains completely closed.

(2) Pilot Spill

When the coil is no longer energized, the pilot valve opens and a small amount of fuel flows out of the main valve chamber. Therefore, the hydraulic pressure of the main valve chamber decreases.

(3) Main Spill

The main valve opens due to the difference in hydraulic pressures, and a large amount of fuel spills from its seat area, thus ending injection.

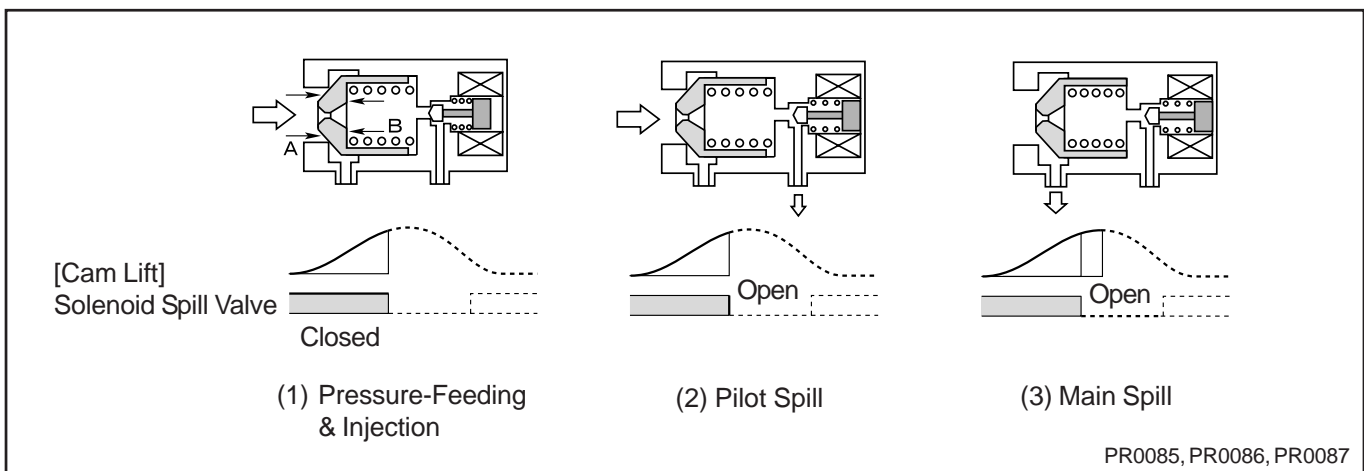

[Reference: Construction and Operation of Solenoid Spill Valve (direct-acting type)]

■ Construction

A direct-acting type solenoid valve is used in order to achieve high levels of response and spill performance.

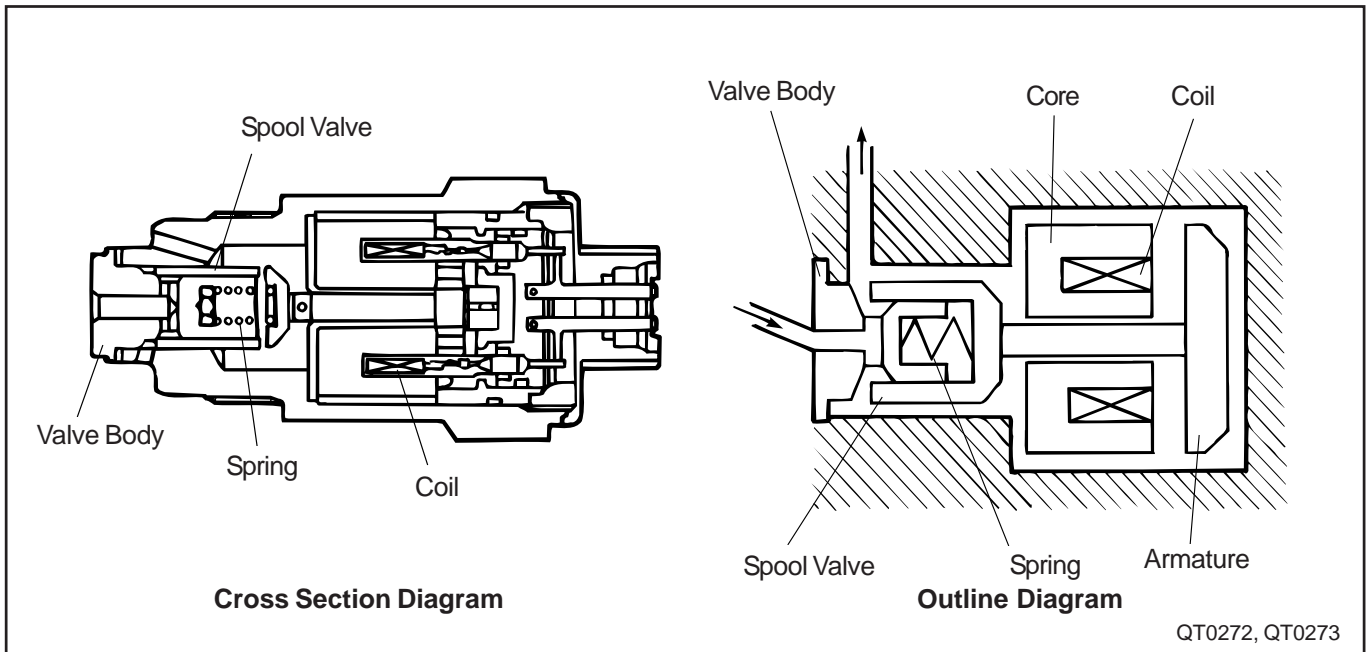

■ Operation

(1) Pressure-Feeding and Injection

When the coil is energized, the armature is pulled into the core. This causes the spool valve to move and come in contact with the valve body, thus making the plunger chamber oil-tight. Then, the ascent of the plunger causes the pressure-feeding and injection of fuel.

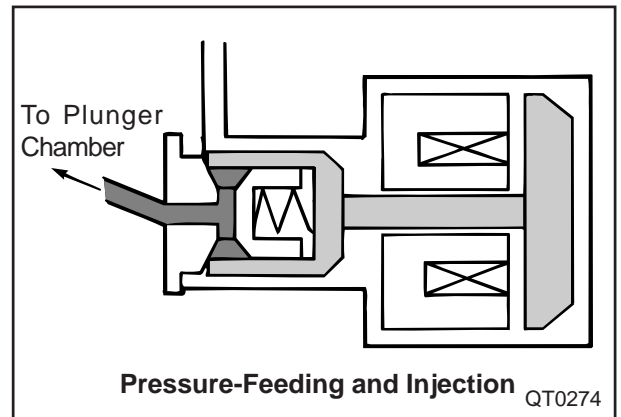

(2) Spill and Suction

When the coil is no longer energized, the reaction of the spring causes the spool valve to open, and the fuel in the plunger chamber spills through the passage in the spool valve, causing the injection to end. Also, fuel enters the valve when the plunger descends.

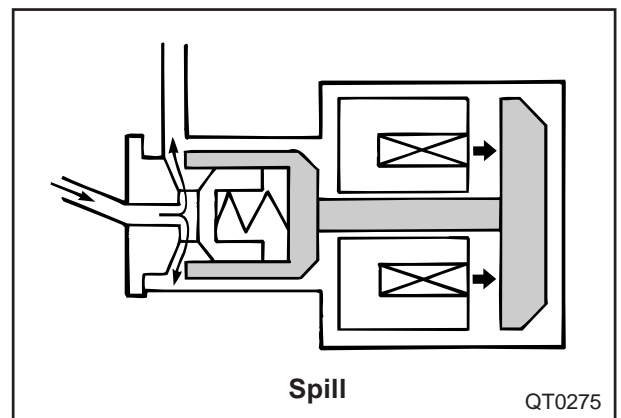

■ Solenoid Spill Valve Actuation Method

Because the solenoid spill valve must operate with a quick response, the coil resistance is kept small to ensure operating current, and current control is effected to prevent overheating.

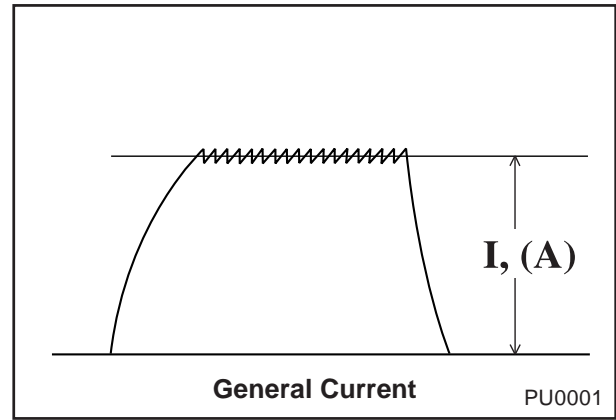

4-4. Relationship Between Vehicle (Engine) and Fuel Injection Volume Control

(1) Load Applied to Engine and Fuel Injection Volume Control

The computer (ECU) determines the injection volume that is optimal for the engine load (vehicle operating conditions) based on the two patterns that follow. One is the “basic injection volume” that is determined by the addition of corrections (which are calculated from the sensor signals) to the value that are based on the engine speed and the acceleration opening. The other is the “maximum injection volume” that specifies the limit of the injection volume in proportion to the air volume that is drawn into the engine.

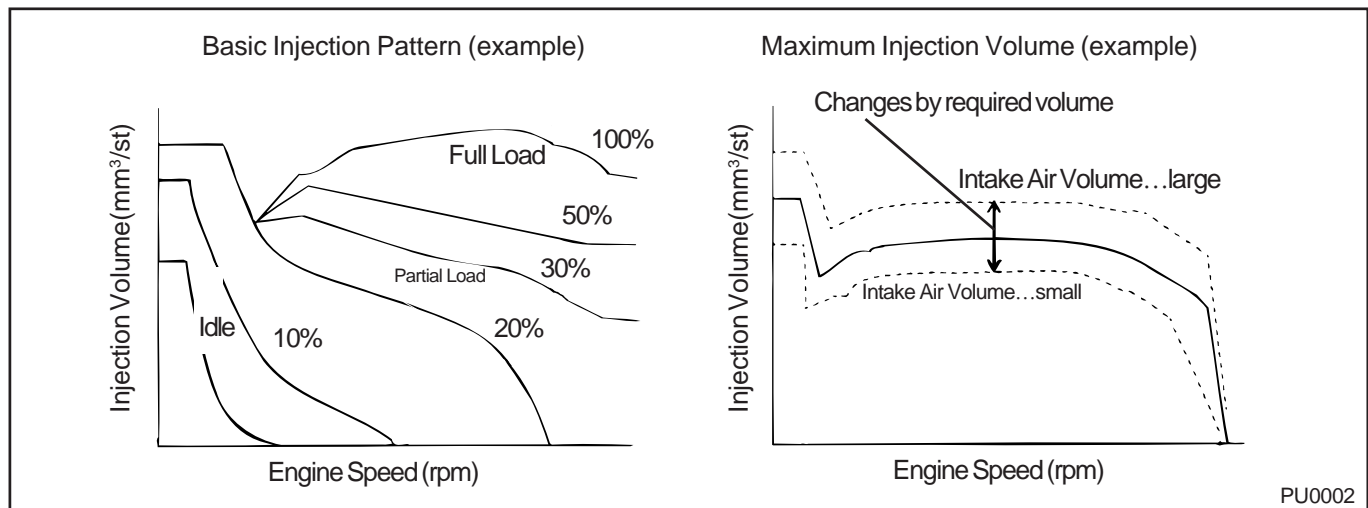

(2) Flowchart for Calculating Injection Volume

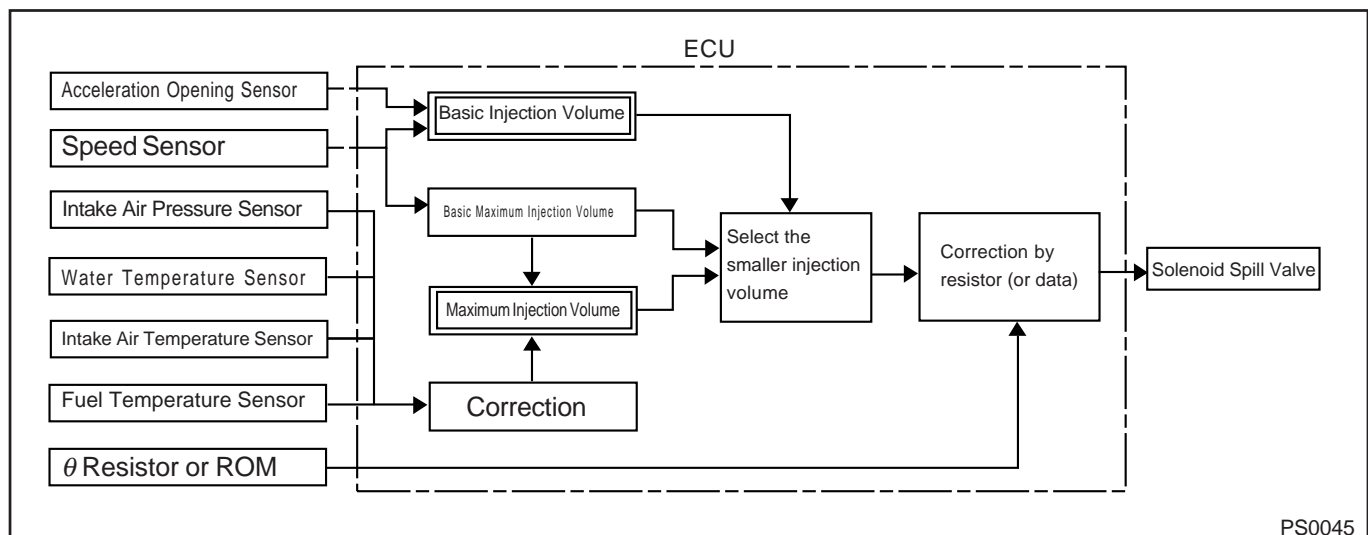

4-5. Final Fuel Injection Volume Decision

(1) Other than starting

The injection volume is determined by using the governor pattern of the map with the smaller injection volume, after comparing the basic injection volume and the maximum injection volume.

(2) Starting

The injection volume is determined based on the basic injection volume, with corrections added in accordance with the starter and water temperature sensor signals. If the coolant temperature is lower than the specified value (10°C), a simulated acceleration opening is created to calculate the injection volume.

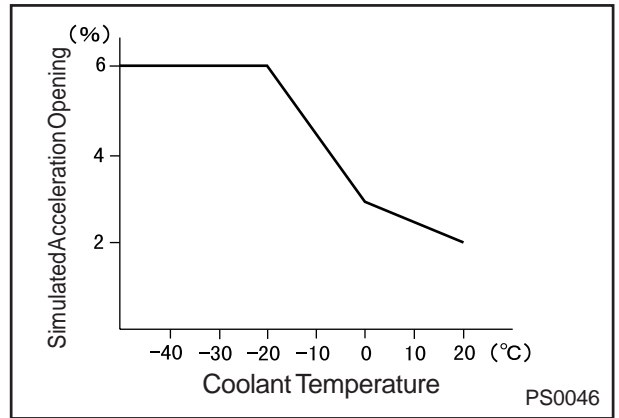

4-6. Various Types of Fuel Injection Volume Corrections

(1) Intake Air Pressure Correction

The intake air volume is calculated based on the signals from the turbo pressure sensor so that the maximum injection volume can be corrected towards the increase side if supercharging is occurring. On some engine models, the correction coefficient is decreased during the transitional period in which the EGR and IDL (idle) switches are turned from ON to OFF.

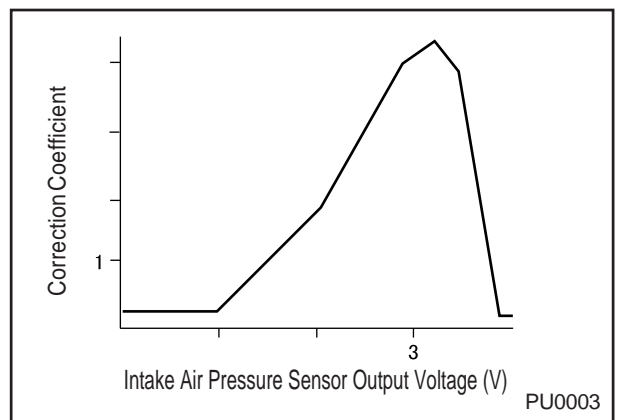

(2) Intake Air Temperature Correction

The air density varies by its temperature when air is drawn in, and this causes a variance in the air-fuel ratio. Therefore, the higher the intake air temperature, the greater the correction that must be made to reduce the injection volume, through the use of the signals from the intake air temperature sensor.

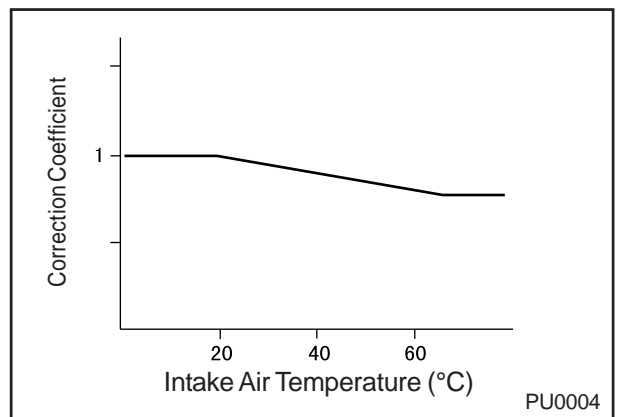

(3) Fuel Temperature Correction

When the temperature of the fuel changes, its volume as well as the amount of its leakage during pumping changes. Therefore, the actual injection volume changes and creates a variance in the air-fuel ratio. Therefore, the higher the fuel temperature, the greater the correction that must be made, in order to increase the injection volume.

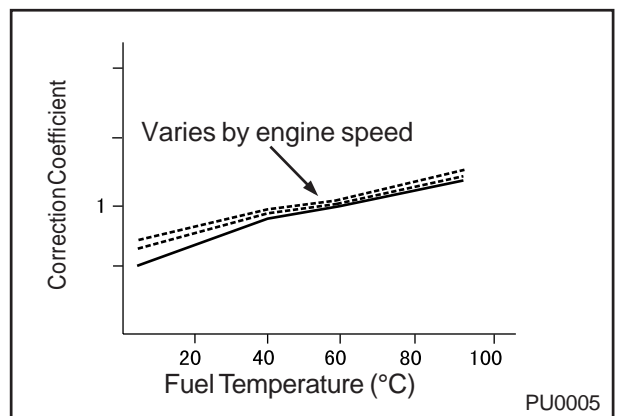

(4) Cold Temperature Correction

To improve the operation of a cold engine, a correction is made to enrich the air-fuel ratio by increasing the injection volume when the coolant temperature is low. After the correction starts, the injection volume is decreased at a prescribed rate.

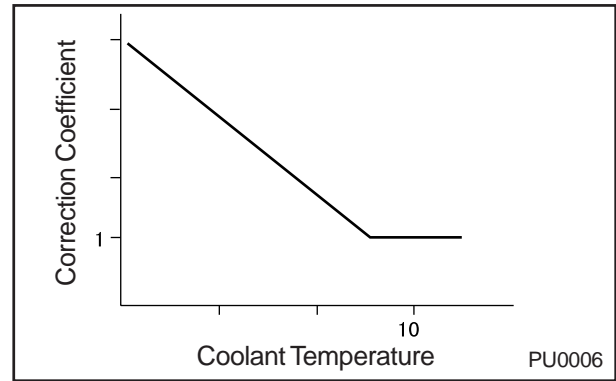

(5) Deceleration Correction

When the vehicle decelerates suddenly as a result of sudden braking, the drop in the engine speed could cause the engine to stall or to operate poorly. To prevent this situation, this correction increases the injection volume and allows the engine speed to decrease smoothly.

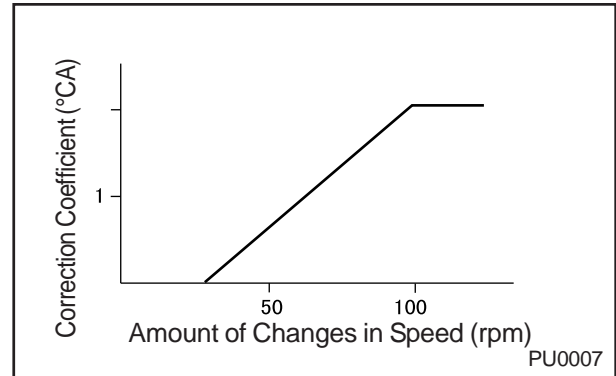

(6) Injection Volume Correction θ Resistors (or ROM)

These resistors or ROM data are used for adjusting the phase of the cam angle (°CA) calculated by the computer in order to make a correction to the final injection volume. In the case of correction resistors, the greater their resistance, the higher the VRP terminal voltage will be, and the correction is made to increase the volume. However, if the VRP terminal voltage is abnormal, the fail-safe function uses the map data in the computer to apply a prescribed amount of correction. In the case of the ROM, detailed data that is matched to the characteristics of the individual pumps are stored so that a more detailed and higher precision correction can be applied. Furthermore, the data on the ROM can be rewritten in order to set finely tuned correction values at will.

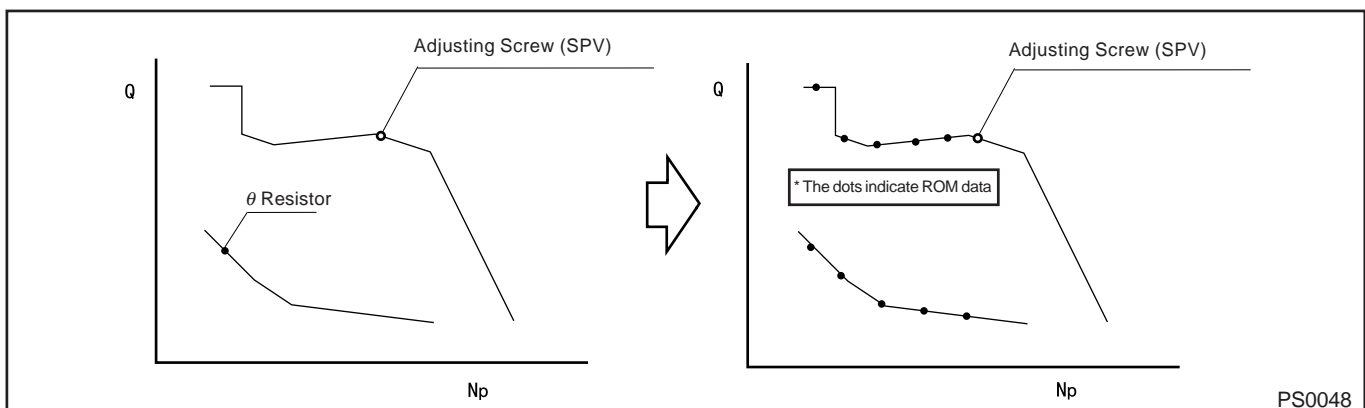
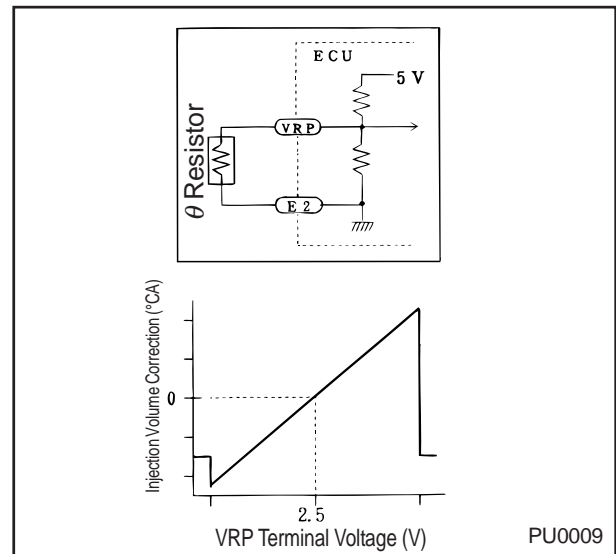

(7) Idle Vibration Reduction Control

To reduce engine vibrations during idle, this control compares the time between the cylinders, and regulates the injection volume for each cylinder if there is a significant difference so that the engine can operate more smoothly.

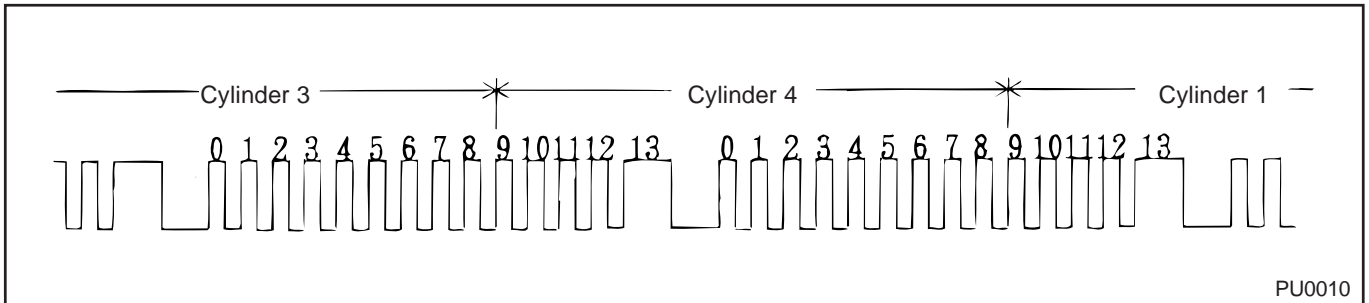

(8) Speed Correction Control of Injection Volume

When the speed of the injection pump increases, the fuel injection volume increases due to the response lag of the solenoid spill valve. This correction is made because the fuel injection volume varies by engine speed even if the injection angle remains the same.

(9) Gradual Control of Fuel Injection Volume

This control makes a correction so that the engine accelerates smoothly, instead of increasing the injection volume in accordance with the acceleration opening. It prevents the emission of black smoke or poor operation due to the sudden increase in the fuel injection volume during acceleration. Conversely, during deceleration, this control gradually decreases the injection volume in order to minimize the torque fluctuation.

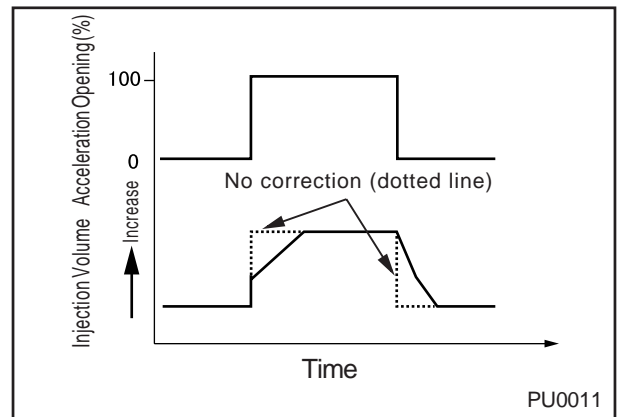

(10) ECT Control (on automatic transmission vehicles)

This control reduces the shocks that result from the torque fluctuations that occur during the shifting of an electronically controlled transmission (ECT). To do so, this control momentarily reduces the power of the engine by reducing the injection volume during shifting.

4-7. Summary of Injection Volume Control

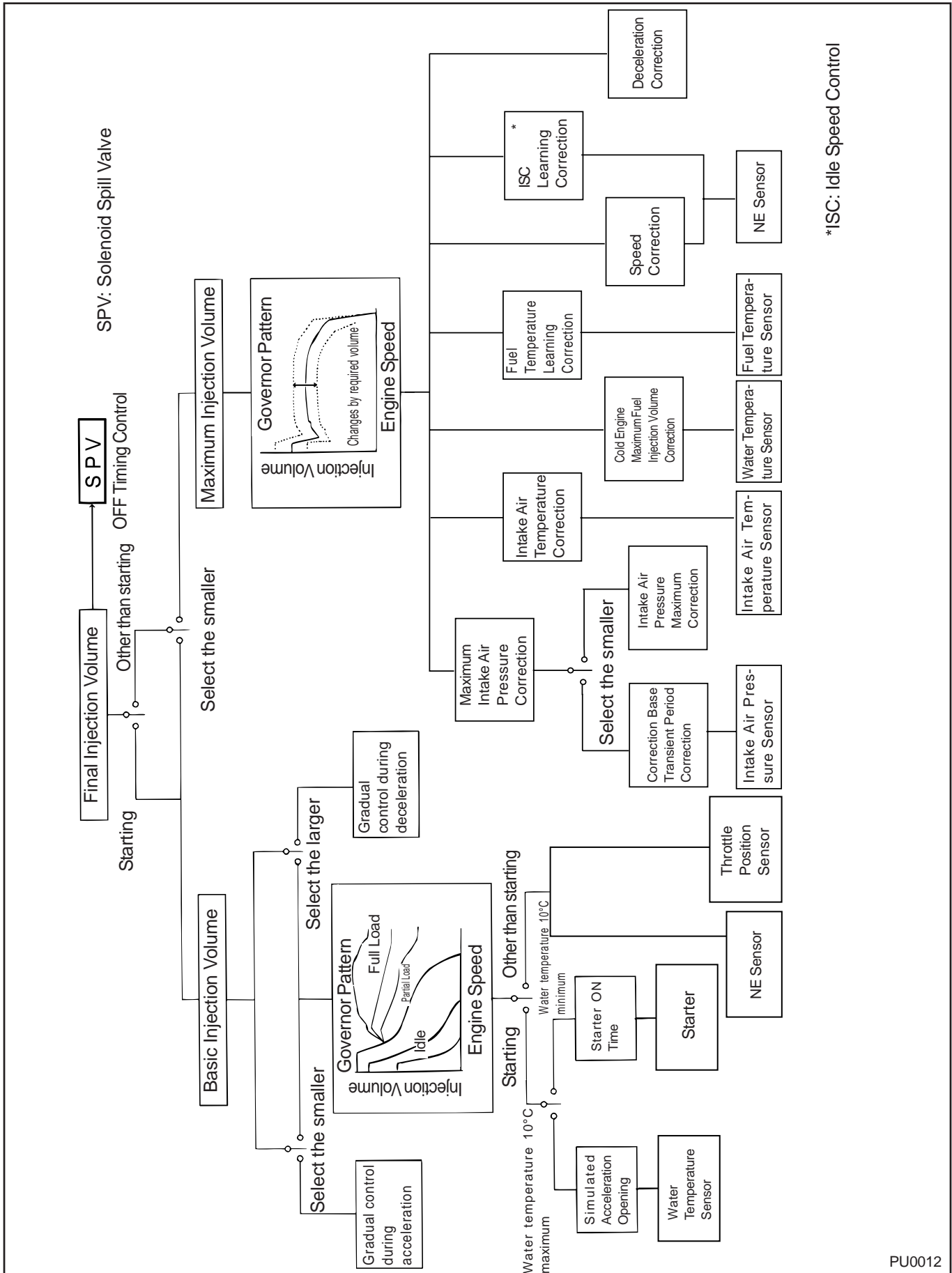

[Reference: Maximum Fuel Injection Volume Calculation Flow Chart]

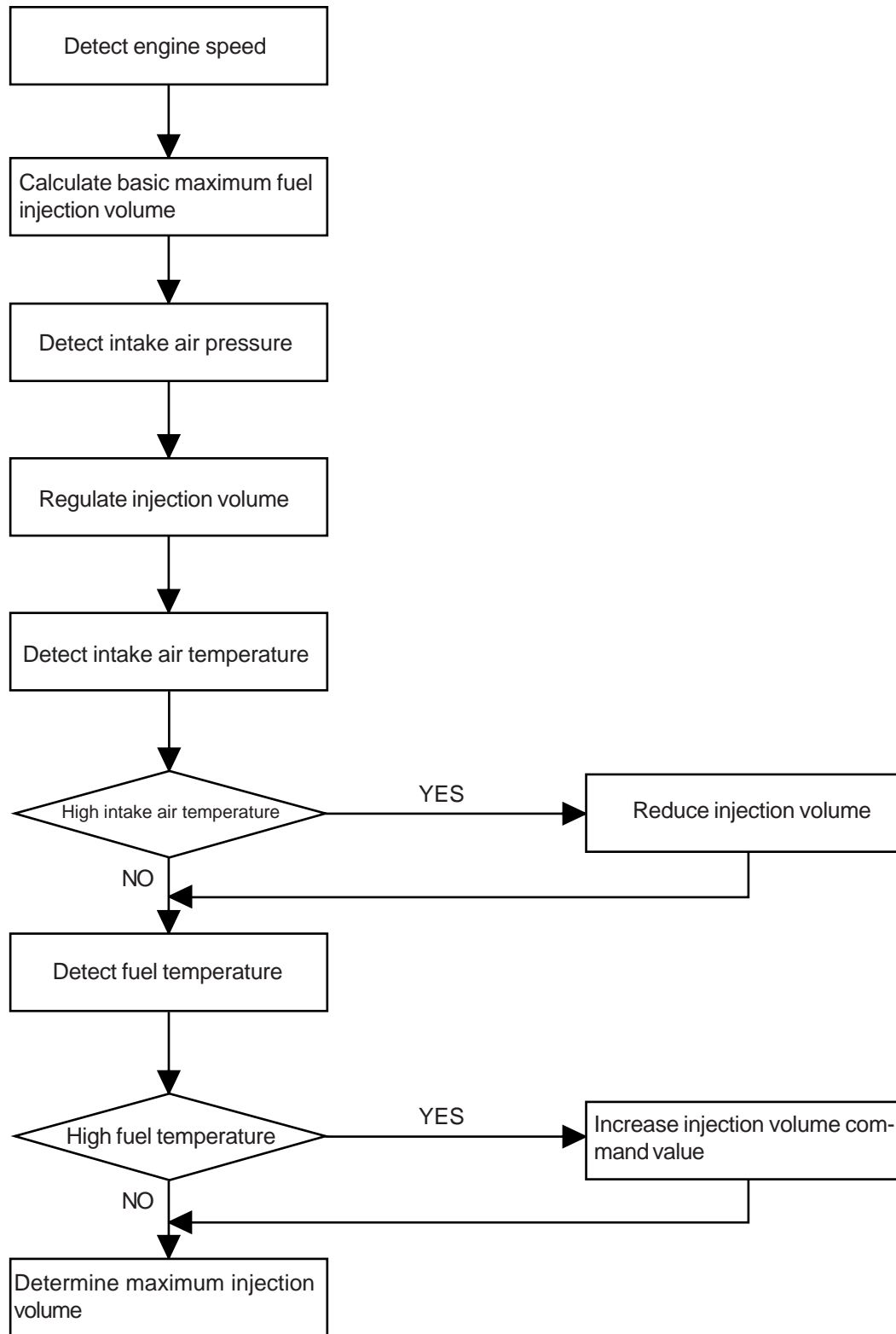

PS0049

5. Fuel Injection Timing Control

5-1. Outline of Fuel Injection Timing Control

The computer detects the conditions of the engine in accordance with the signals received from the sensors. Then, it calculates the injection timing that is optimal for those conditions. The results are then sent to the timing control valve (TCV) in order to control the injection timing.

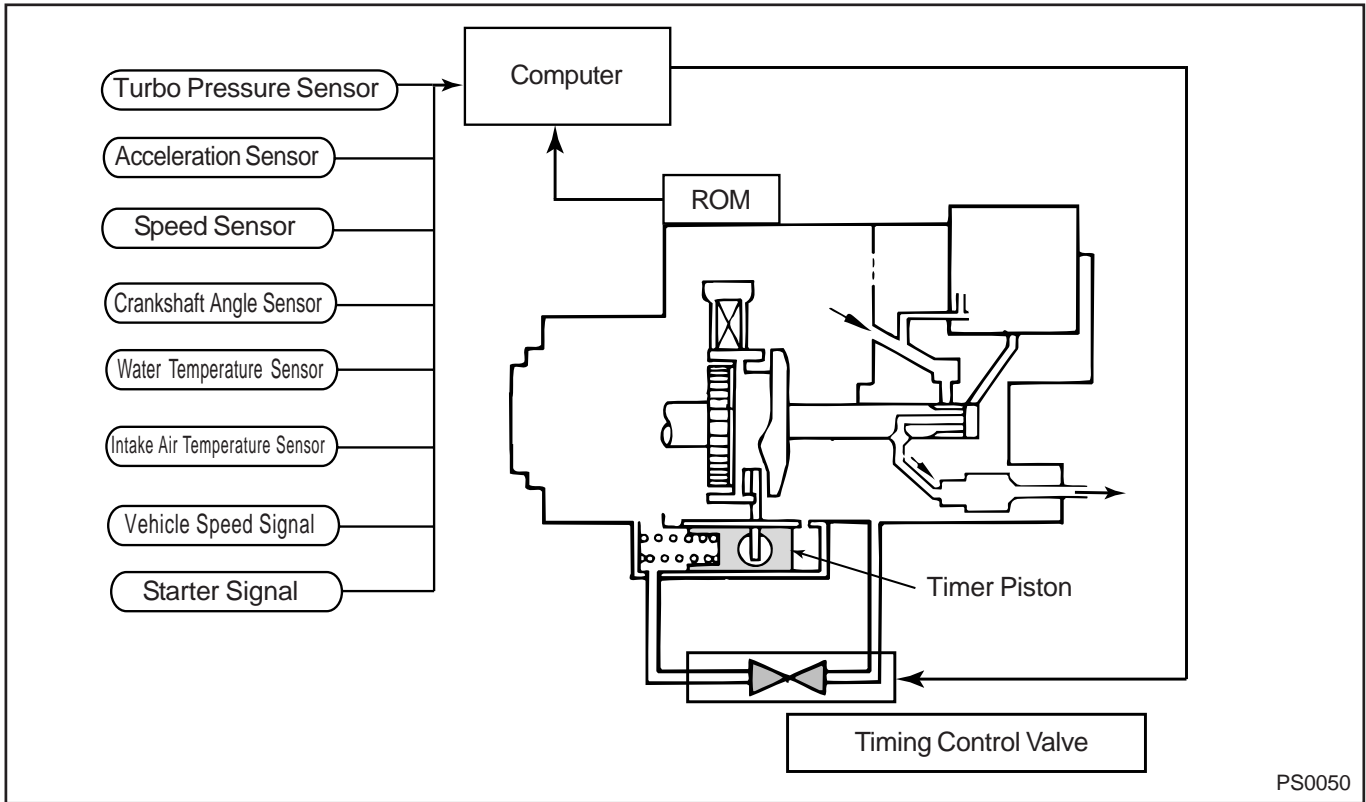

5-2. Components

(1) Crankshaft Position Sensor

This sensor is mounted on the engine block, and a protrusion is provided on the crankshaft to generate one pulse per revolution of the engine.

These pulses are then sent to the computer in the form of standard crankshaft position signals.

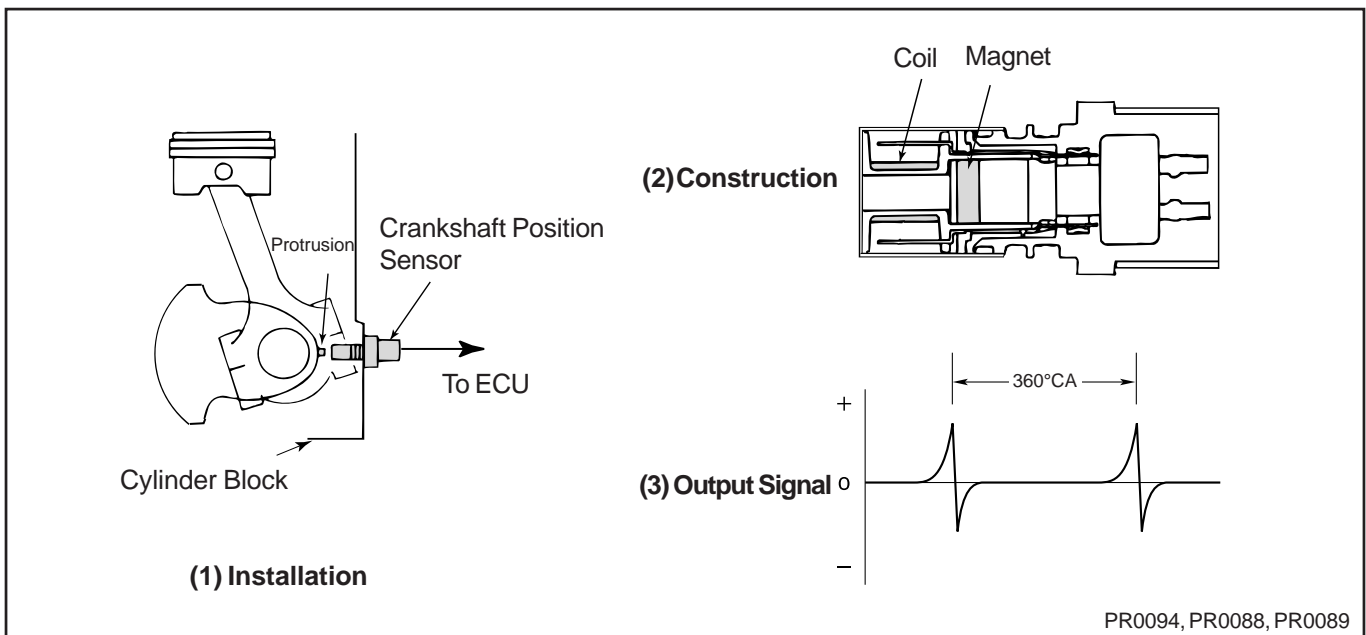

(2) Timing Control Valve (TCV)

The timing control valve (hereafter referred to as "TCV"), which is mounted on the injection pump, opens and closes the fuel passage between the high-pressure and low-pressure chambers of the timer piston in accordance with the signals from the computer.

When current is applied to the coil, the stator core becomes magnetized and retracts the moving core by compressing the spring. As a result, the fuel passage opens.

The opening of the valve is controlled by the computer in accordance with the ratio of the ON/OFF times (duty cycle ratio) of the current that is applied to the coil. The longer the length of the ON time, the longer the valve remains open.

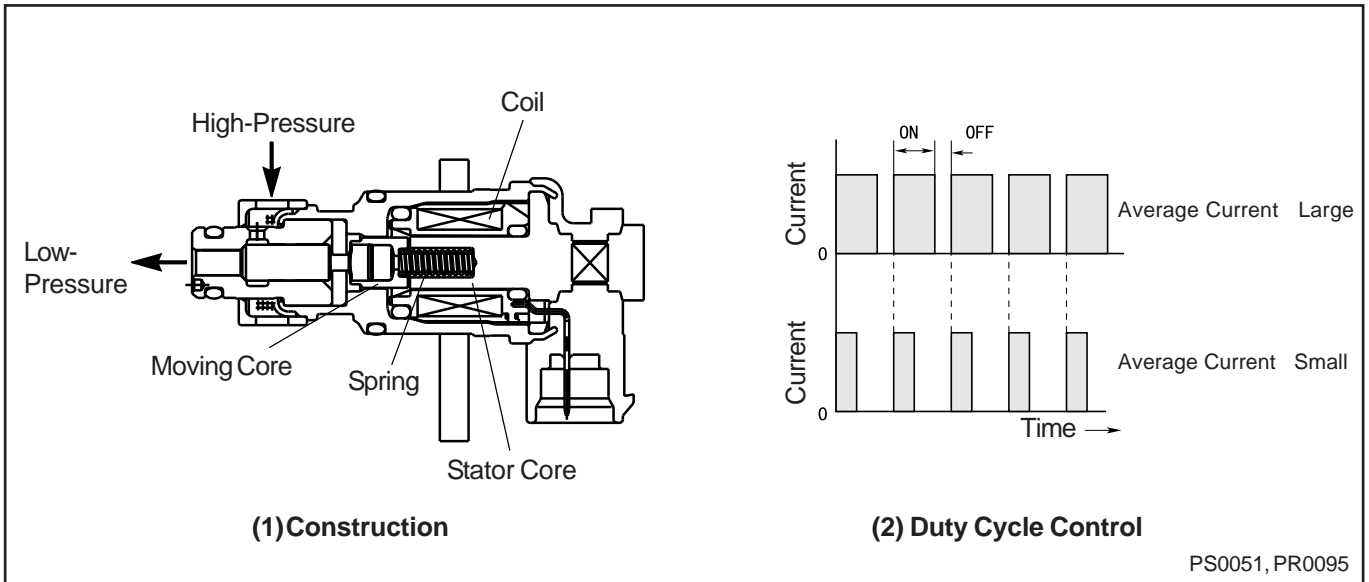

5-3. Injection Timing Control

(1) Injection Timing Control Method

The injection timing is determined by the valve opening time of the TCV that regulates the pump chamber fuel pressure (that is applied to the timer piston) and by moving the roller ring to effect control.

The longer the valve opening time of the TCV, the greater the volume of fuel that bypasses from the high-pressure side of the timer piston to the low-pressure (suction) side. Therefore, the spring force moves the timer piston in the retard direction.

When the valve opening time of the TCV is short, the timer piston moves in the advance direction.

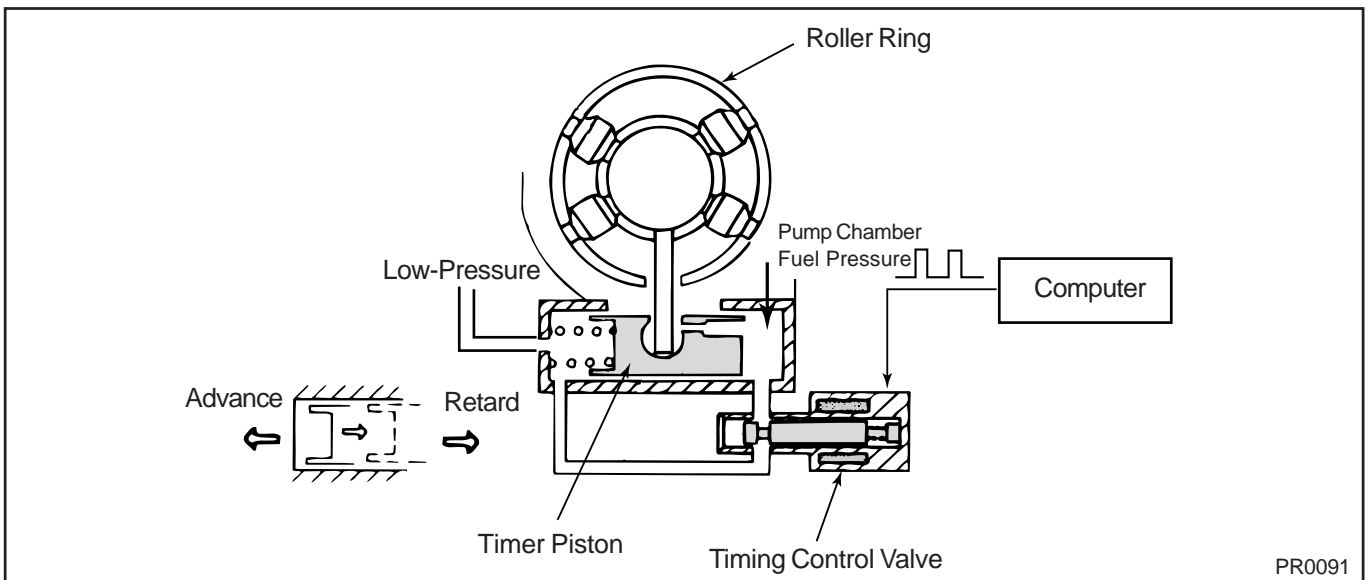

(2) Injection Timing Calculation

Based on the target injection timing (target crankshaft position), the computer makes corrections in accordance with the signals received from the sensors in order to calculate the injection timing that is optimal for the operating conditions of the engine. Furthermore, the computer utilizes the crankshaft position signal (TDC) from the crankshaft position sensor to calculate the actual crankshaft position, which is then fed back to the target injection timing.

a. Target Injection Timing

The target injection timing is calculated based on the acceleration opening and engine speed.

b. Injection Timing Correction

The injection timing is corrected based on the intake air pressure and coolant water temperature.

c. Starting Injection Timing

During starting, the target injection timing is corrected in accordance with the starter signal, coolant water temperature, and engine speed.

Example: 3C-TE Engine

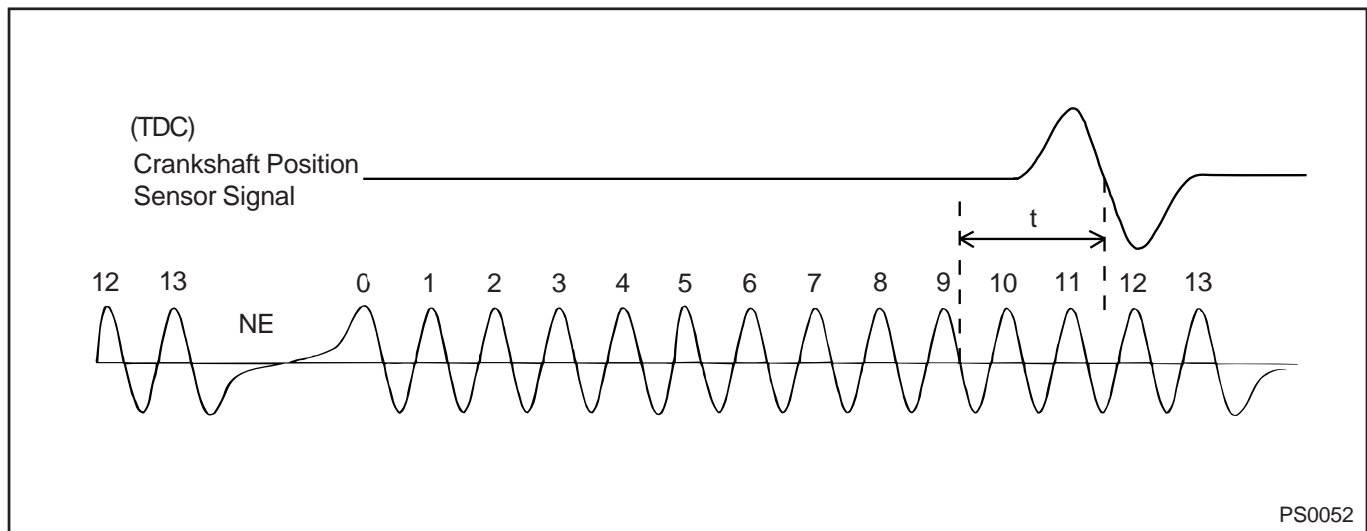

(3) Target Injection Timing and Final Injection Timing Calculation Flow Chart

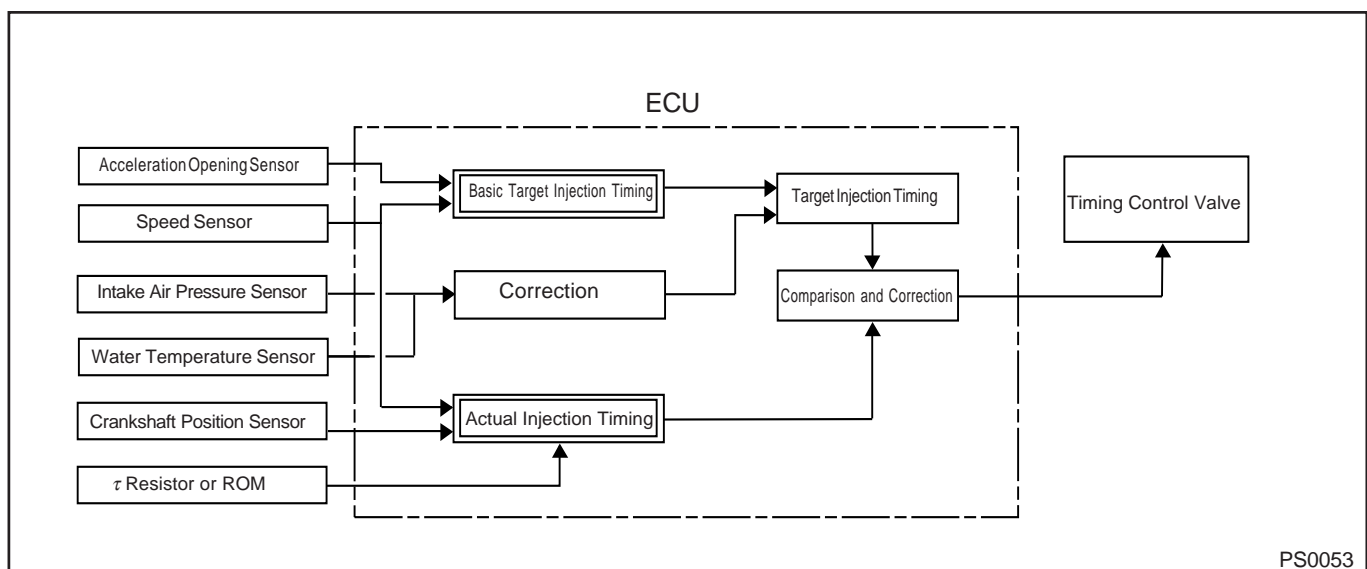

[Reference]

■ Feedback Control

This function effects control on the timing angle θ between the actual compression top-dead-center and the start of injection, as shown in the diagram. However, the actual compression top-dead-center and the injection waveform cannot be detected in the form of signals. Therefore, the actual injection timing must be calculated as follows.

(1) Actual Injection Timing Calculation

- On the engine, there is a correlation between the compression top-dead-center and the TDC signal of the crankshaft position sensor.
- Also, on the pump, there is a correlation between the injection waveform and the NE pulse of the speed sensor.
- Therefore, the actual injection timing can be obtained by calculating the phase difference $\theta 1$ between the TDC signal and the NE pulse.

(2) Feedback Control

This function corrects the duty cycle ratio of the TCV so that the actual injection timing matches the target injection timing.

■ Relationship Between Injection Timing and Injection Volume

The injection timing is controlled by varying the position of the timer piston, which is linked to the roller ring that determines the start of pressure-feeding.

Thus, the ending injection timing also advances in the same amount that the starting injection timing has advanced. Therefore, the injection volume is not affected by the injection timing.

The changes in the position of the roller ring do not alter the relationship between the cam lift and the NE pulse, which is associated with the injection volume control. This is because the speed sensor is mounted on top of the roller ring and moves in unison with the roller ring.

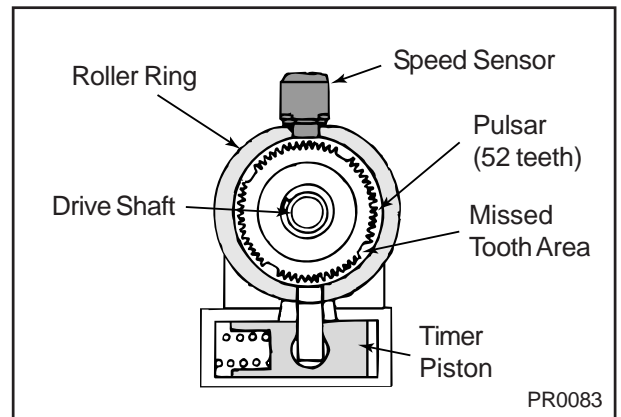
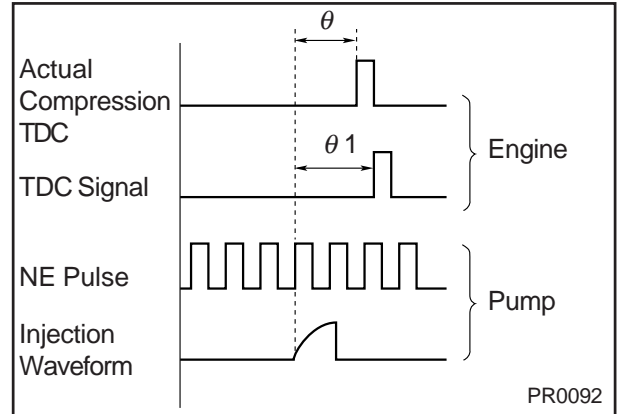

5-4. Final Injection Timing Decision

(1) Other than starting

Target injection = basic target injection timing
 + cold correction advance
 + intake air pressure correction advance

(2) Starting

Starting target injection = starting basic target crankshaft position
 + starting water temperature correction

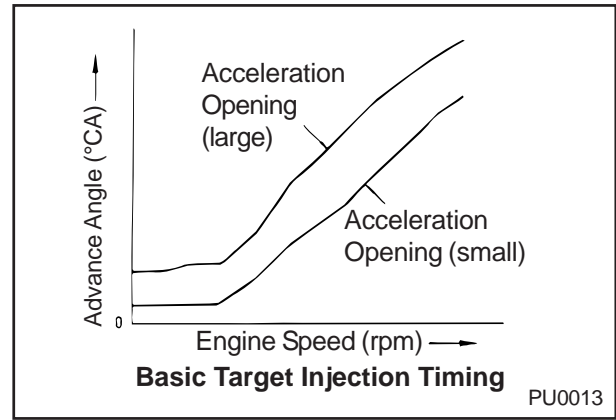

5-5. Fuel Injection Timing Correction

(1) Intake Air Pressure Correction Advance

The amount of correction advance is calculated based on the intake air pressure sensor signal (intake air pressure) and the engine speed.

Reference: Other Specifications

Model	ECD-V3	ECD-V3
Engine	1KZ-TE	3C-TE
Maximum Correction Advance	6°CA	5°CA
0°CA condition	3200 rpm minimum	4000 rpm minimum

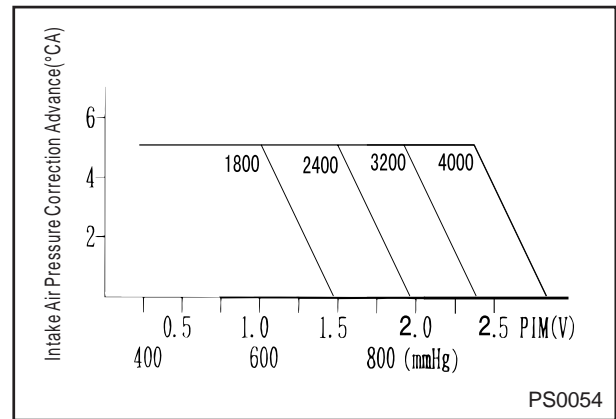

(2) Cold Correction Advance

The amount of correction advance is calculated based on the water temperature sensor signal (coolant water temperature) and the engine speed. On some engine models, the calculation is made through interpolation in accordance with the map data in the ECU.

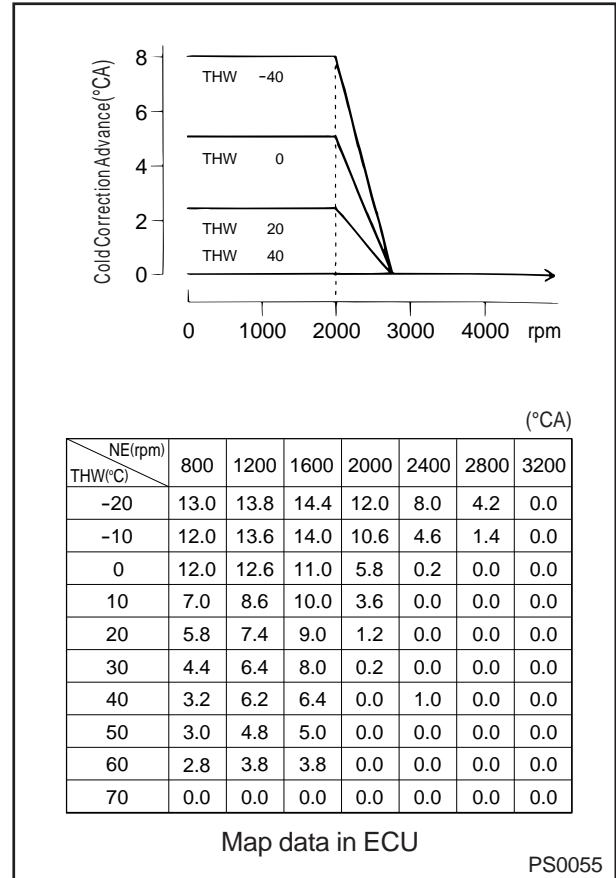

(3) Starting Duty Cycle Ratio

When the engine has just been started and its speed is low, the TCV is actuated by the duty cycle ratio that is determined by the coolant water temperature. At this time, the lower the coolant water temperature the smaller the duty cycle will be, causing the injection timing to advance. In particular, when the engine exceeds the specified speed, a correction based on water temperature will be applied to the “starting target injection timing”.

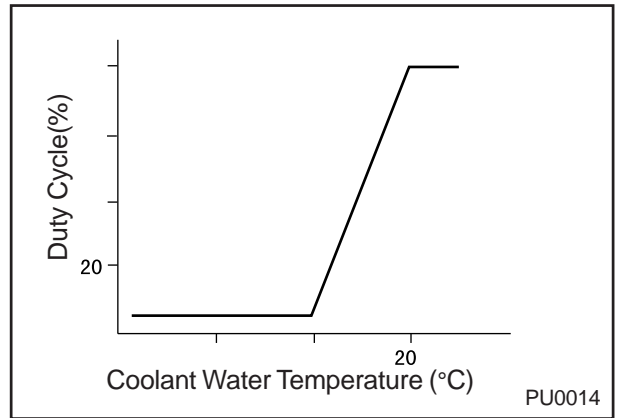

(4) Starting Basic Target Crankshaft Position

After starting, when the engine speed increases to a certain level, the basic target crankshaft position that is predetermined according to speeds is applied.

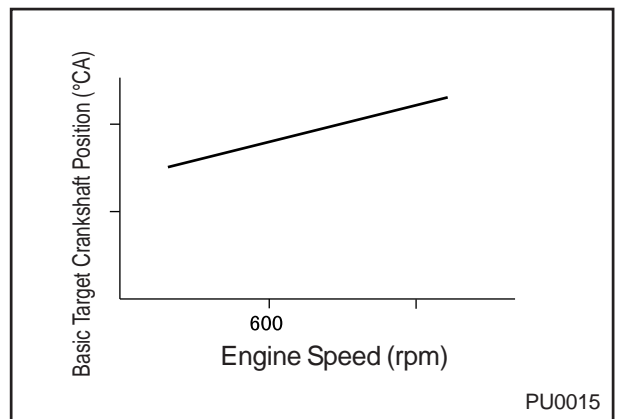

(5) Starting Water Temperature Correction

When the coolant water temperature is low, a correction is applied to the starting target injection timing.

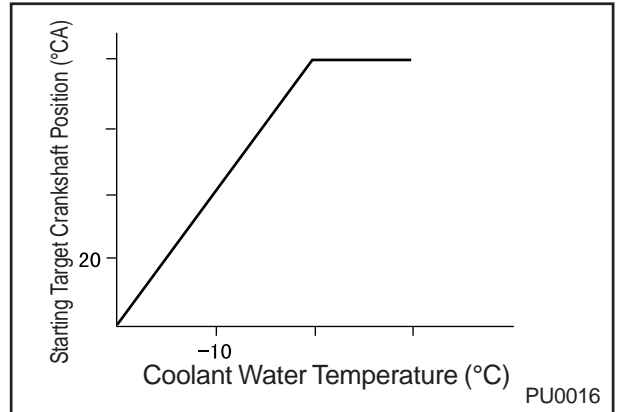

(6) Crankshaft Position Correction Resistor τ (or ROM)

The NE pulse (cam angle signal) that is detected by the speed sensor is used for controlling the injection timing. However, a deviation in the correlation between the cam angle signal and the injection waveform that exists between the individual pumps causes the injection timing to also deviate. This deviation is therefore corrected through the use of the correction resistor τ or the correction data on the ROM.

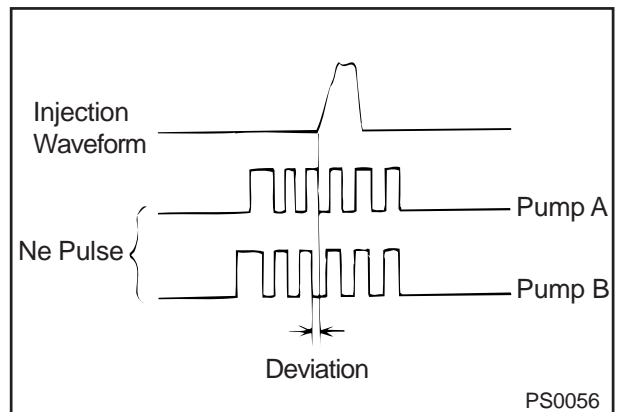

5-6. Timing Control Valve (TCV) Actuation Method

(1) Fixed Duty Cycle Control

When the engine is being started (starter turned ON, and engine operating at low speeds), the engine has stalled (ignition switch turned ON), or the crankshaft position sensor is defective, the TCV is actuated in accordance with the duty cycle ratio that is fixed to the actuation frequency that has been prescribed for the respective condition.

(2) SPV (Solenoid Spill Valve) Synchronization Control

When the TCV is turned from ON to OFF, the fuel pressure in the pump causes pulsation, which affects the injection volume and injection timing. Therefore, the TCV operation is synchronized to the actuation of the SPV at engine speeds other than the prescribed speeds. As a result, the influences of the pulsation are minimized.

(3) Ordinary Control

The TCV is controlled by varying the duty cycle ratio in accordance with the operating conditions, except when it is under fixed duty cycle control or SPV synchronization control.

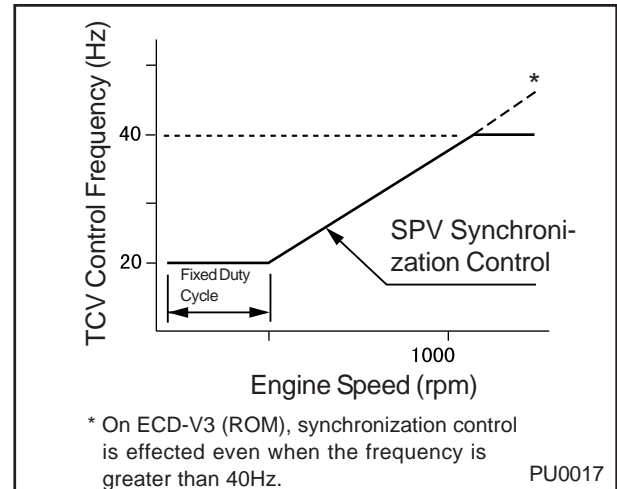

5-7. Summary of Injection Timing Control (representative examples)

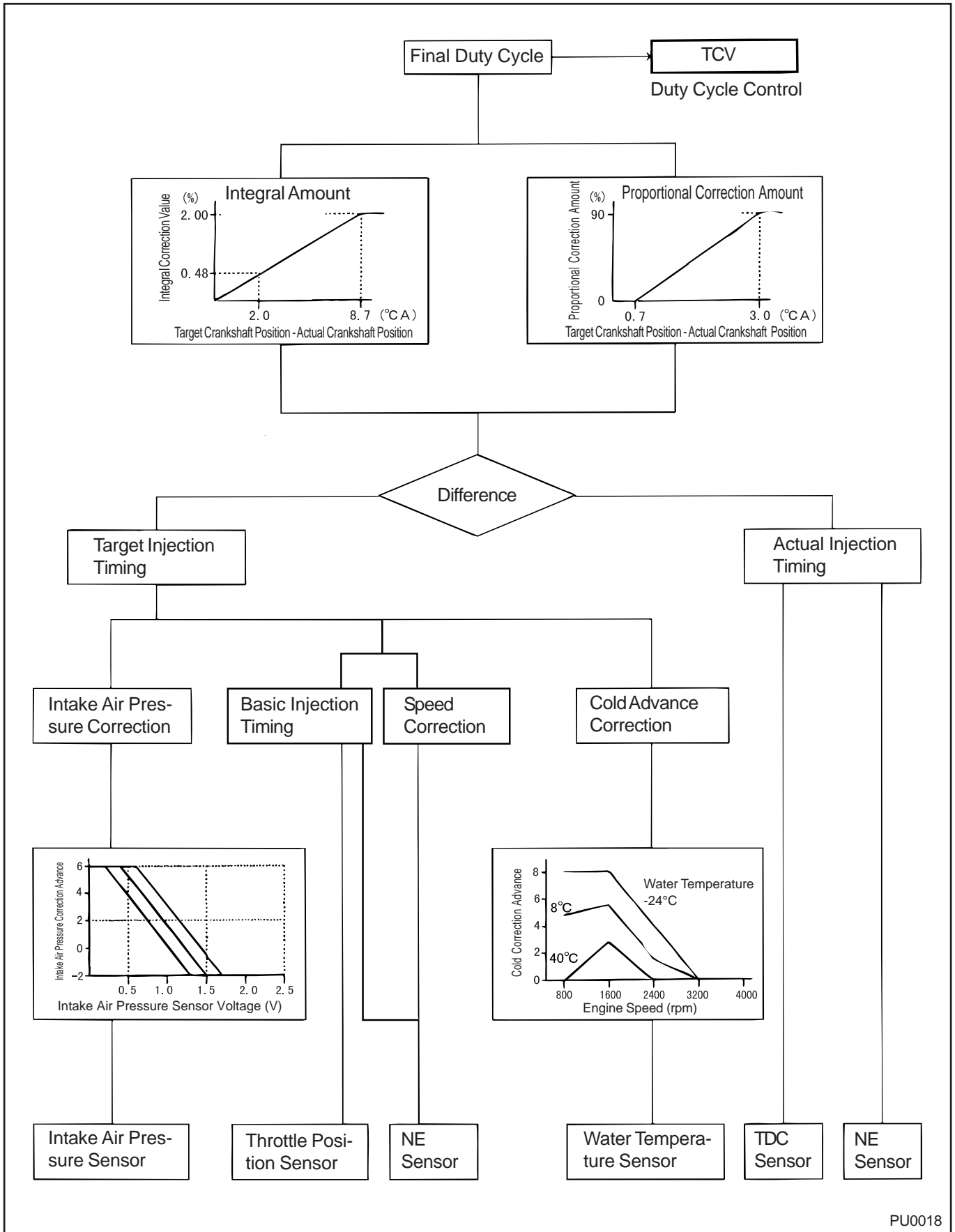

[Reference: Fuel Injection Timing Calculation Flowchart]

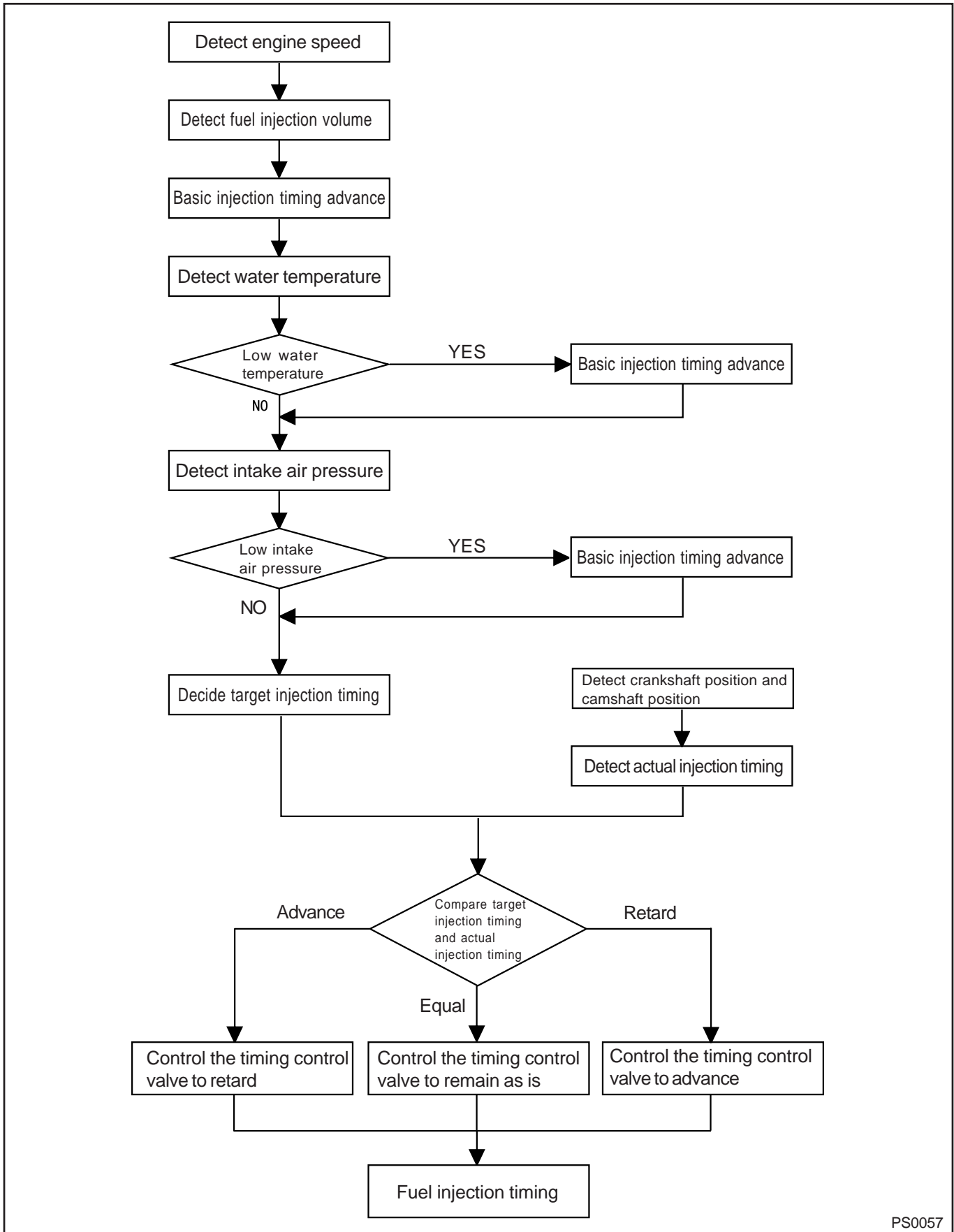

PS0057

6. Idle Speed Control

6-1. Outline

The computer calculates the target speed in accordance with the operating conditions of the engine and determines the injection volume in order to control the idle speed.

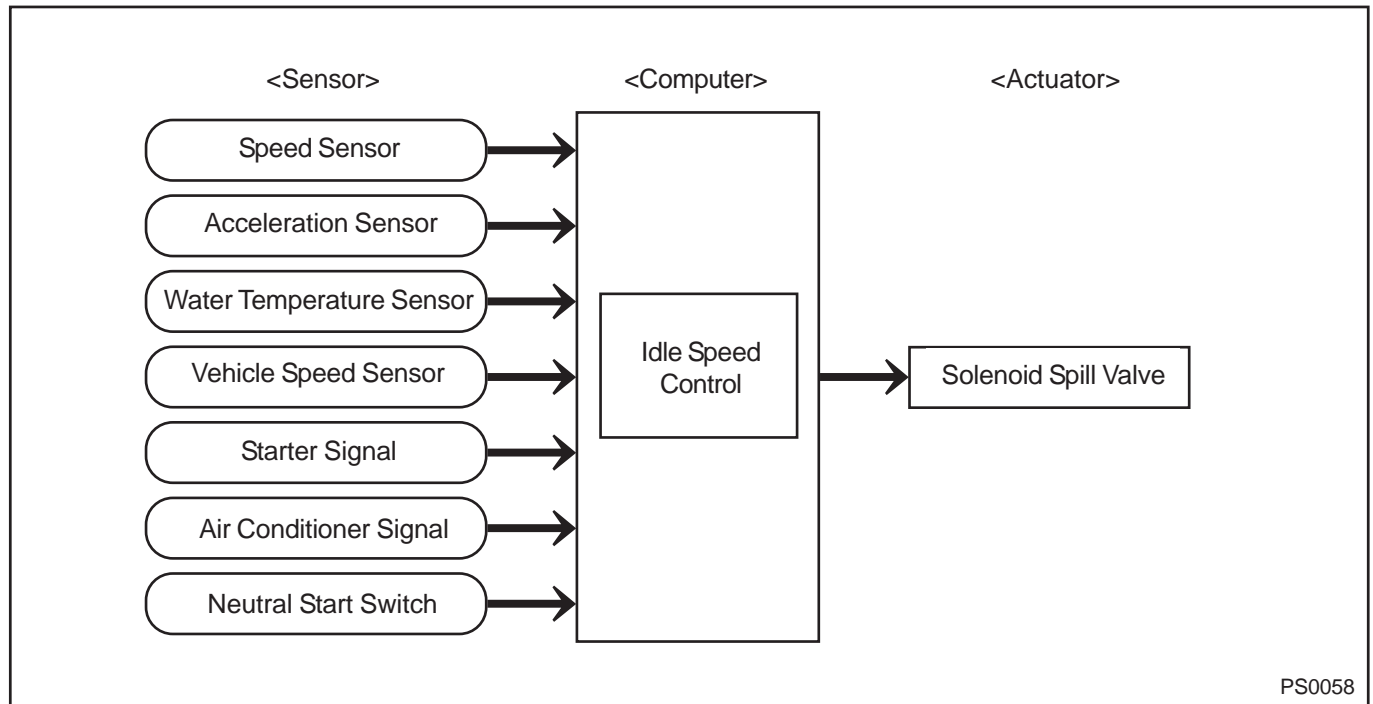

6-2. Idle Speed Control

(1) Feedback Control

The computer compares the target idle speed and the engine speed (speed sensor signal) at that time. If a difference exists, the computer controls the injection volume so that the engine speed matches the target idle speed.

■ Example of Idle Speed (3C-TE engine)

The ON/OFF (air conditioner signals) conditions of the air conditioner are detected to control the idle speed.

- Air conditioner ON: 850 rpm
- Air conditioner OFF: 750 rpm

(2) Warm-Up Control

In accordance with the coolant water temperature, this function controls the engine to a fast idle speed that is optimal for warming up the engine.

In addition, the computer effects "prospective control" in which the idle speed is changed beforehand only for a prescribed amount. This prevents the idle speed from fluctuating due to the changes in the engine load, such as when the air conditioner is turned ON or OFF.

There is also an idle vibration reduction control function that corrects the injection volume of the cylinders by detecting any speed fluctuations per cylinder.

7. Intake Air Venturi Control

This control regulates the intake air volume by controlling the sub-valve in the venturi, which is provided in the intake manifold, in three stages: fully open, half open, and fully closed. Some pumps are provided with a single-valve type that uses only the main valve, such as the vacuum type independent venturi or the electronically controlled type that uses a step motor.

7-1. Function

ComponentName	Function
Actuator (dual-stage actuator)	Opens and closes the sub-valve.
VSV	Switches the vacuum and atmospheric pressure that is applied to the dual-stage actuator.
Throttle Position Sensor	Detects the acceleration opening.
Speed Sensor	Detects the engine speed.
Water Temperature Sensor	Detects the coolant water temperature.
Engine Control Computer	Sends signals to the VSV and opens and closes the sub-valve in three stages.

QN0071

7-2. Construction

(1) Venturi

The standard types of venturis are the dual-valve type that contains main and sub valves, and the single-valve type that contains only the main valve.

In the case of the dual-valve type, a throttle position sensor, which detects the throttle opening, is mounted on the main throttle valve. (In case of the single-valve type, the sensor is also mounted on the main valve.)

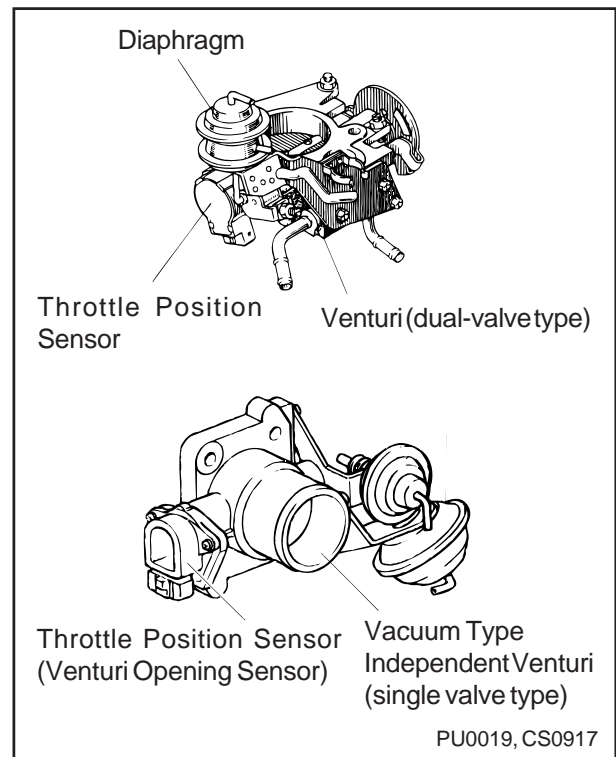

(2) VSV

Switches the vacuum and the atmospheric pressure that is applied to the actuator in accordance with the signals from the engine control computer (ECU).

Specifications

○—○ air passage

	Port E	Port F	Atmospheric Port
ON	○—○		
OFF	○		○

QN0072

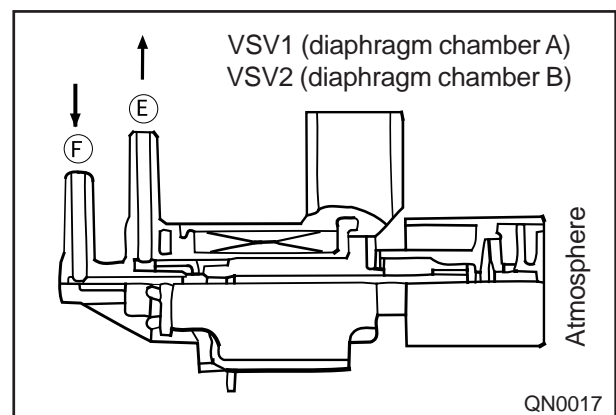

7-3. Operation

(1) Cold, Fully Closed Acceleration, and High-Speed Operation

The engine control computer detects the coolant water temperature in accordance with the signals from the water temperature sensor. When the engine is cold, it turns OFF both VSV1 and VSV2. This introduces atmospheric pressure to both chambers A and B in the actuator, allowing the sub-valve to open fully. As a result, practically no restriction will be applied to the intake air volume during idling.

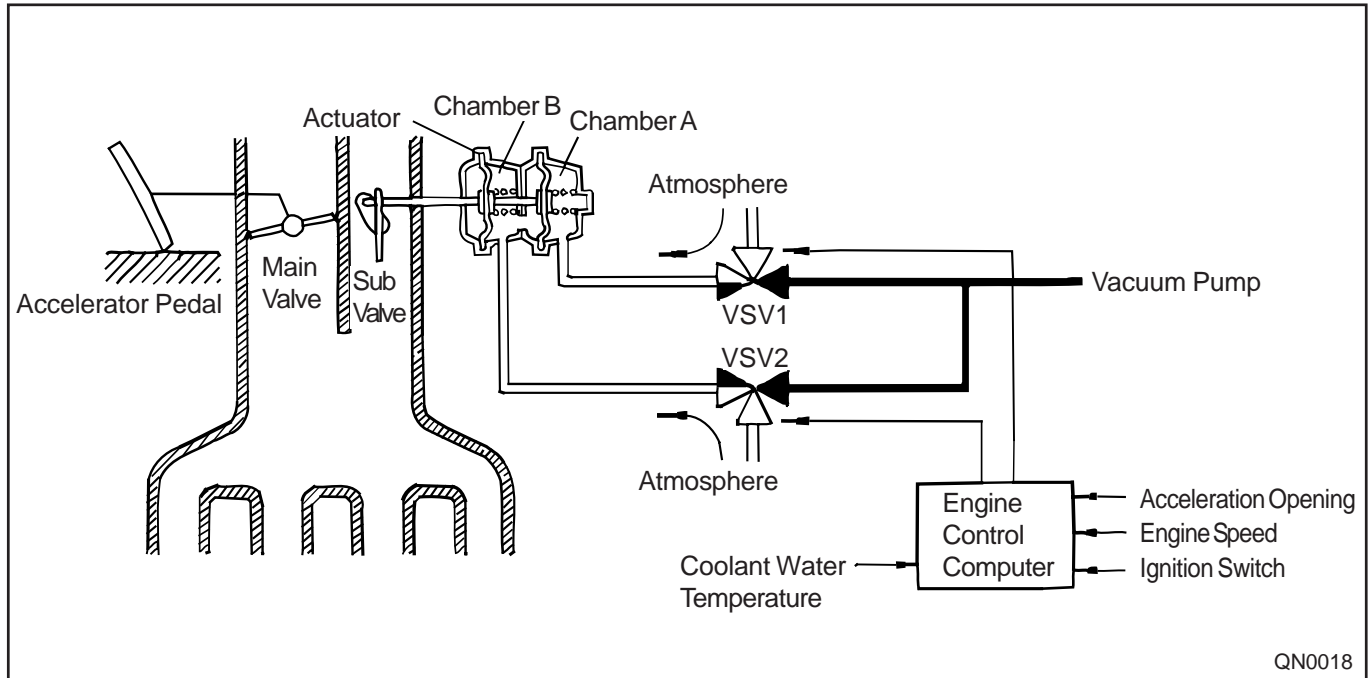

(2) Normal Driving (after warm-up)

After the engine has warmed up at idle, the engine control computer turns VSV1 off, and VSV2 ON. This introduces atmospheric pressure to chamber A in the actuator and vacuum from the vacuum pump to chamber B. As a result, the sub-valve opens to a certain extent (half open).

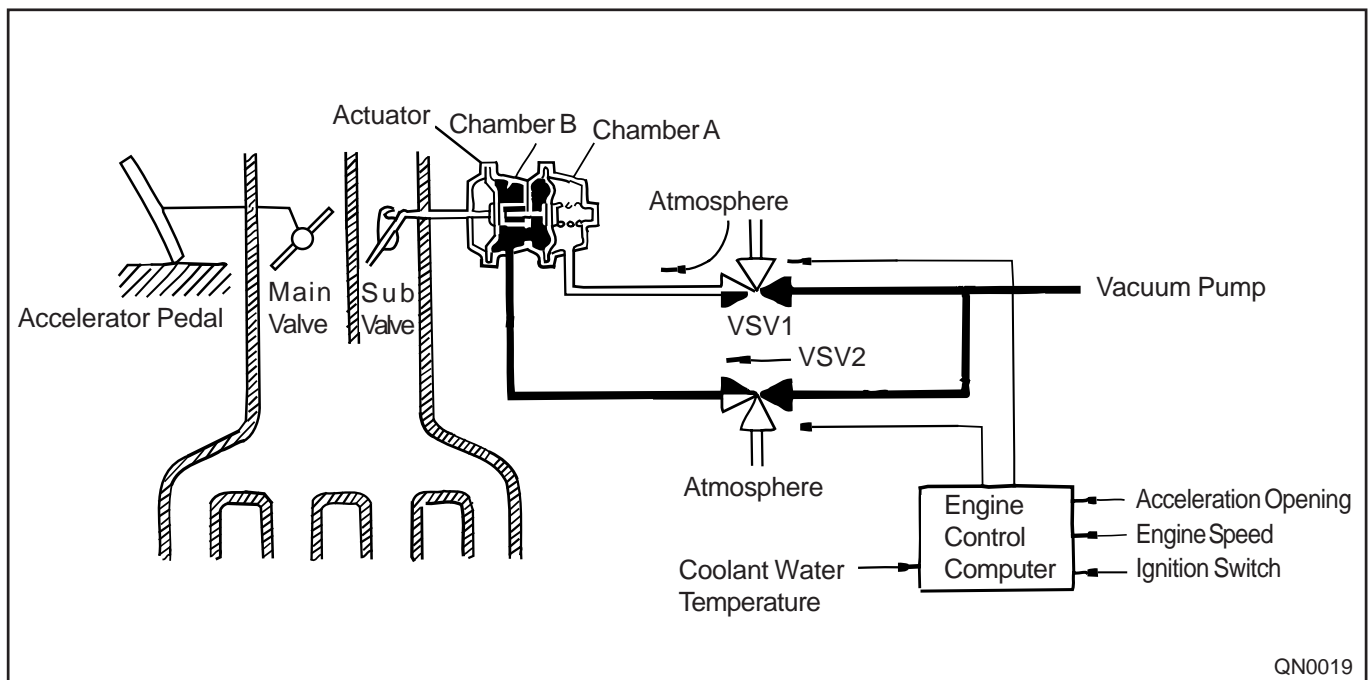

(3) Stopping the Engine

When the ignition switch is turned OFF, the engine control computer turns ON VSV1 and VSV2. This introduces the vacuum from the vacuum pump to chambers A and B in the actuator. As a result, the sub-valve closes fully.

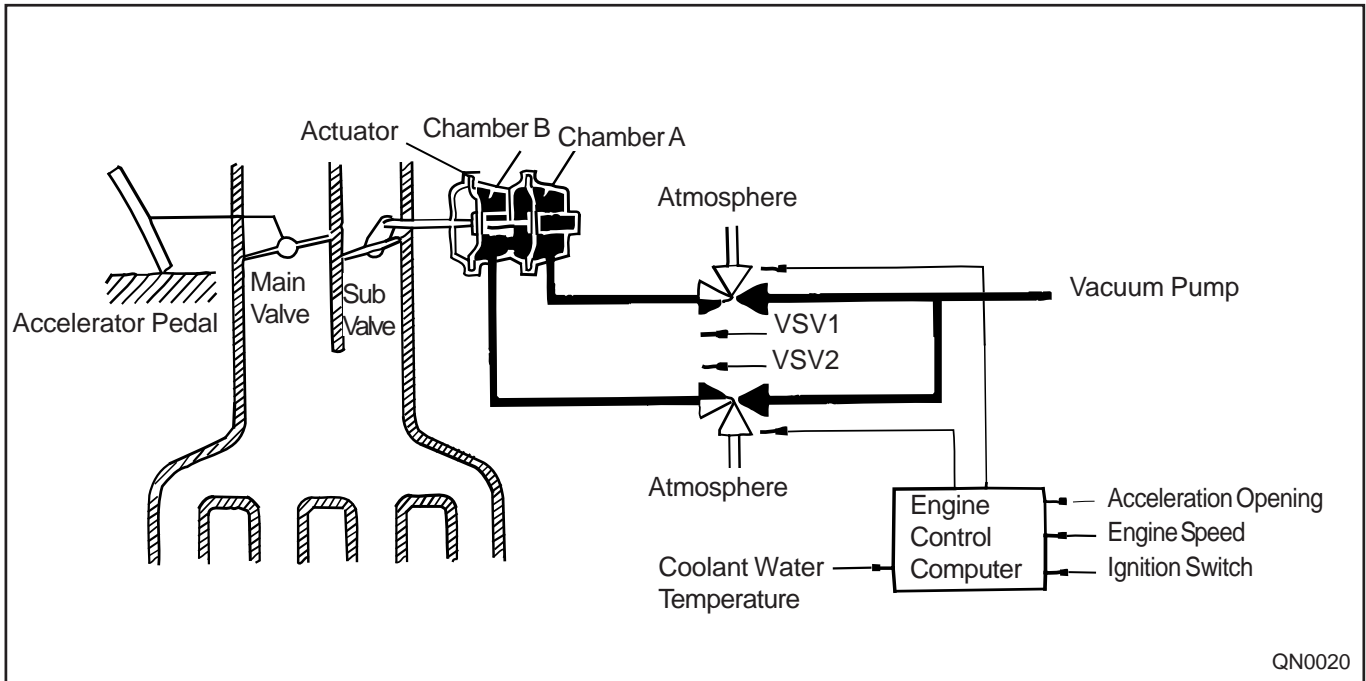

[Reference: Single-Valve Type Venturi Intake Restriction Control (Example: Vacuum Type Independent Venturi)]

■ Outline

In contrast to the dual-valve type that contains a main valve and a sub-valve in the venturi, this type controls the intake air with a single throttle valve (main valve).

Basic Control

Throttle Valve Condition	Control Actuator	Control Valve
Idle ↔ Fully Open	Main Actuator	E-VRV
Fully Closed	Main & Sub-Actuators	E-VRV, VSV

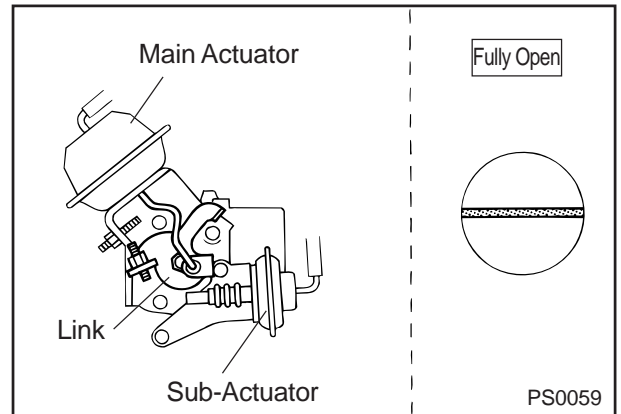

■ Throttle Valve Opening and Operatin Conditions

(1) Fully Open

- Starting (starter signal: ON)
- During driving (fully open acceleration during rapid acceleration)
- Outside air temperature 10°C maximum

(2) Between idle↔fully open (partial acceleration)

- During warm-up (coolant water temperature 59°C maximum)
- During driving (after warming up completely, idle switch: OFF)

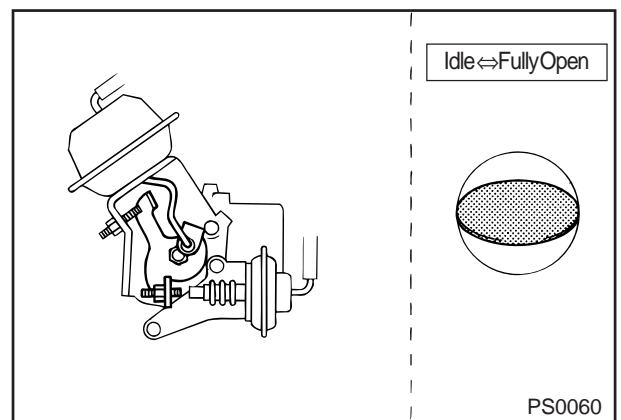

(3) Idling

- Idling after warm-up
- Engine stalling

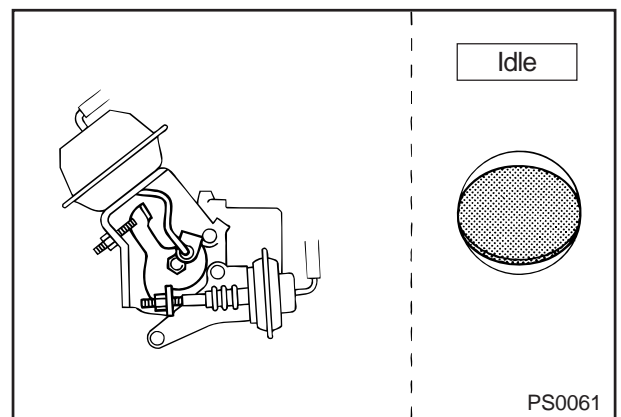

(4) Fully closed

- Engine stopped (ignition: OFF) and immediately thereafter
- When an abnormally high engine speed is detected
- When the solenoid spill valve is malfunctioning
- When the computer is malfunctioning

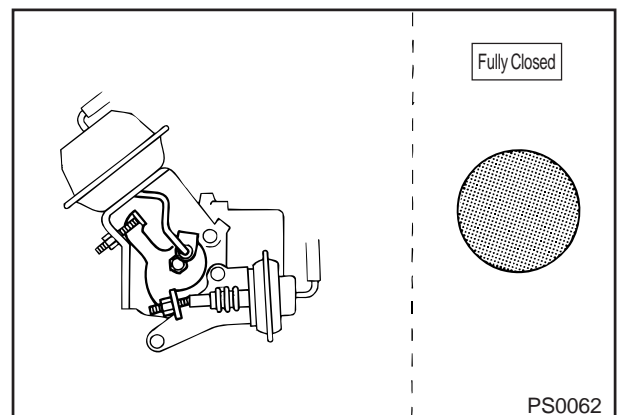

[Reference: Singel-Valve Type Venturi Intake Air Restriction ontrrol (Example: Electronically Controlled Type Venturi [made by another company])

■ Outline

This is a type of vacuum-controlled venturi that has adopted a step motor to make an electronically controlled venturi.

(1) Intake Air Restriction Valve

The newly developed electronically controlled intake air restriction mechanism uses a step motor, which is controlled by the control unit, to actuate the intake air restriction valve in order to achieve high-precision and optimal EGR volume in all operating ranges. When the engine is stopped, this valve closes fully to allow the engine to stop smoothly.

Note: To prevent the throttle valve position from becoming altered, this part cannot be disassembled.

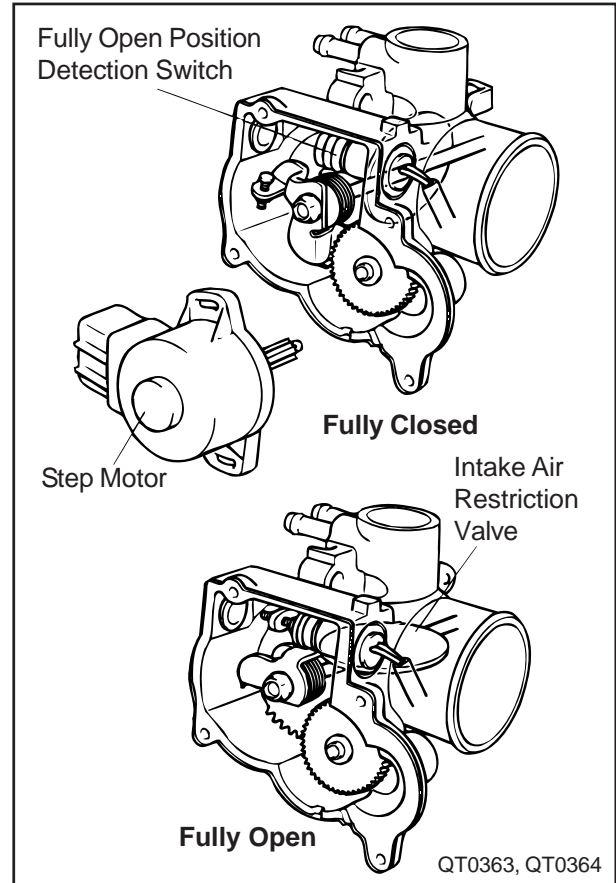

(2) Step Motor

The coil in the motor is energized in accordance with the signals received from the engine control computer. The motor then rotates the magnet (rotor) in order to precisely control the opening of the intake air restriction valve.

a. Specifications

Type	4 phase, 32 pole	
Actuation System	2 phase excitation, 1-2 phase excitation	
Resolution [1 step]	2 phase excitation	1°
	1 - 2 phase excitation	0.5°
Amperage	1.2A per phase maximum	
Coil Resistance	20 ± 2 Ω per phase	
Insulation Resistance	10 M Ω minimum	

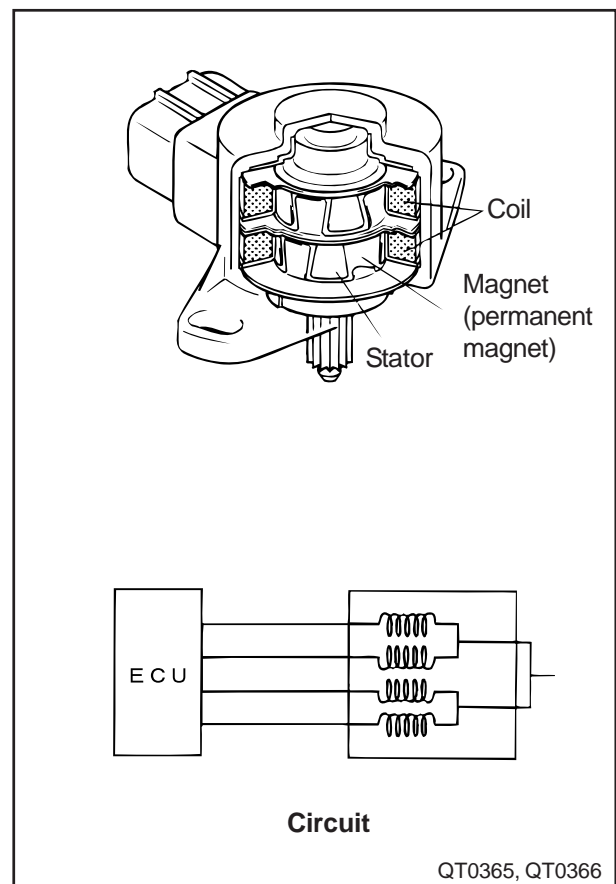

b. Construction

The step motor consists of two layers, and contains two coils, four stators, and magnets that function as a rotor. A stator contains eight tabs, and by having coils placed between them, 16 poles of magnets are arranged alternately.

The two layers of magnets are staggered 11.25° from each other, resulting in a total of 32 poles that actuate the rotor.

Each coil has two sets of coils that are wound in opposite directions, resulting in the two coils having four phases.

The current that is applied to these coils is then switched in order to change the polarity of the stators, thus controlling the rotation and stopping of the rotors.

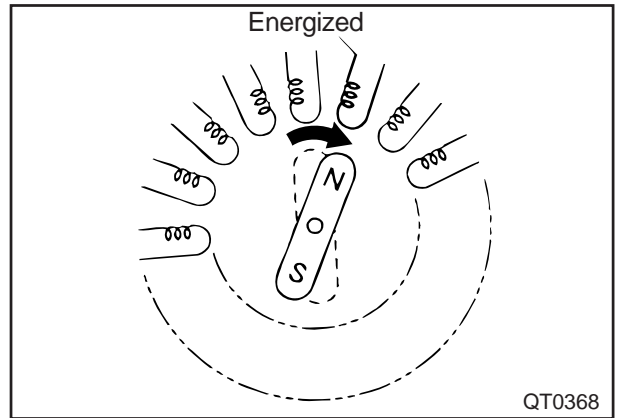
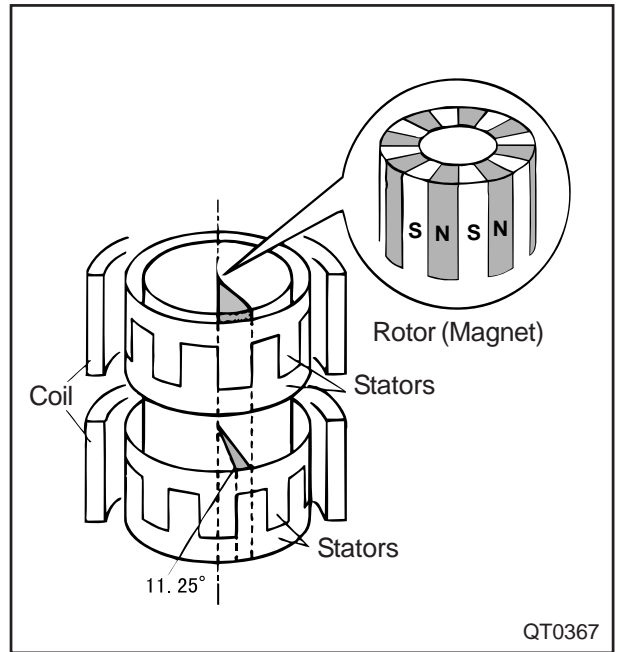

c. Operation

Operation Diagram 1:

When current is applied to coil A, an N-pole magnetic field is generated at the top of the coil, and an S-pole magnetic field is generated at the bottom of the coil. Consequently, an N-pole magnetic field is induced at stator A and an S-pole magnetic field is induced at stator A'. Similarly, when current is applied to coil B, because it is wound in the opposite direction, an S-pole is generated at the top of the coil, and an N-pole is generated at the bottom of the coil. Then, stator B becomes the S-pole and stator B' becomes the N-pole. At this time, the S-pole of the rotor becomes positioned between the N-pole of stator A and the N-pole of stator B'.

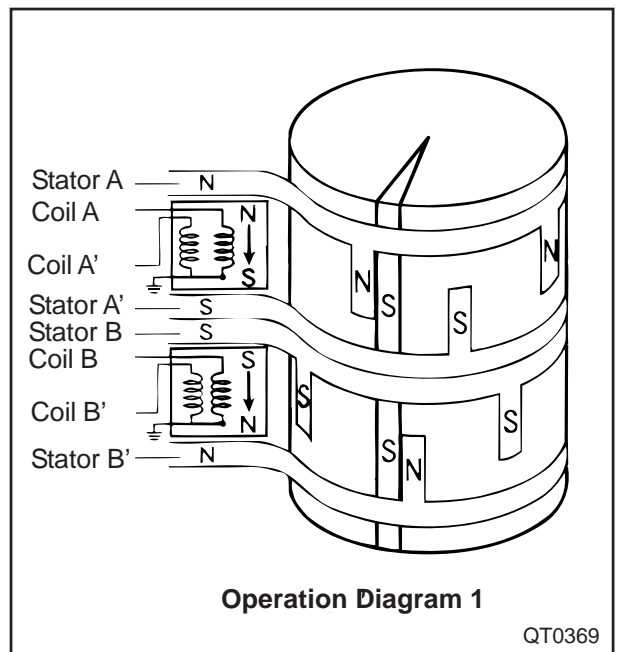

Operation Diagram 2:

If current is applied to coil A' without changing the current that is applied to coil B, the top of coil A' becomes the S-pole and the bottom becomes the N-pole. As a result, a magnetic field of the S-pole is induced to stator A and of the N-pole to stator A'.

The rotor that was positioned in operation diagram 1 rotates upon receiving the reaction force of the polarity changes of the stators.

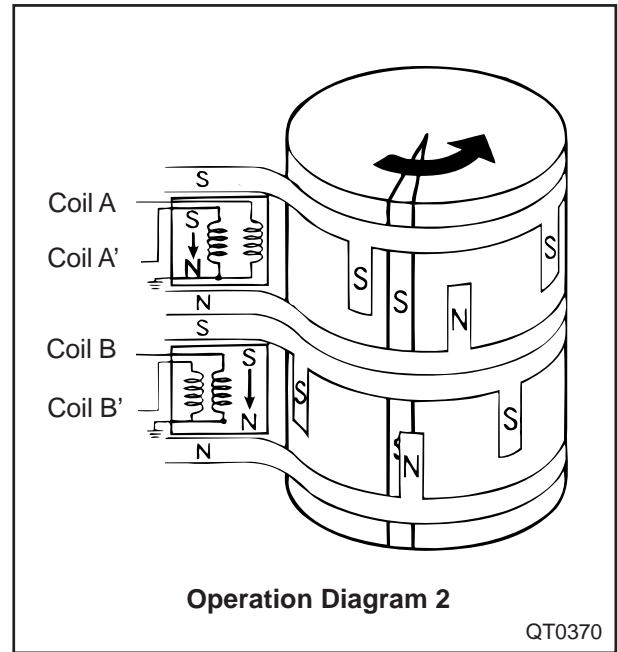

	Excitation 1	Excitation 2	Excitation 3	Excitation 4	Excitation 5 (1)
Polarity of Stator A	(N)	S	(S)	N	(N)
Coil A	ON			ON	ON
Coil A'		ON	ON		
Polarity of Stator A'	S	(N)	N	(S)	S
Operation of Rotor					
Polarity of Stator B	S	(S)	N	(N)	S
Coil B	ON	ON			ON
Coil B'			ON	ON	
Polarity of Stator B'	(N)	N	s	S	(N)

QT0371

8. EGR Control

As part of the countermeasures against exhaust gas emissions, this function recirculates a portion of the exhaust gases by introducing it into the intake air in accordance with the operating conditions. The resultant slowing of combustion helps to restrain the generation of NOx.

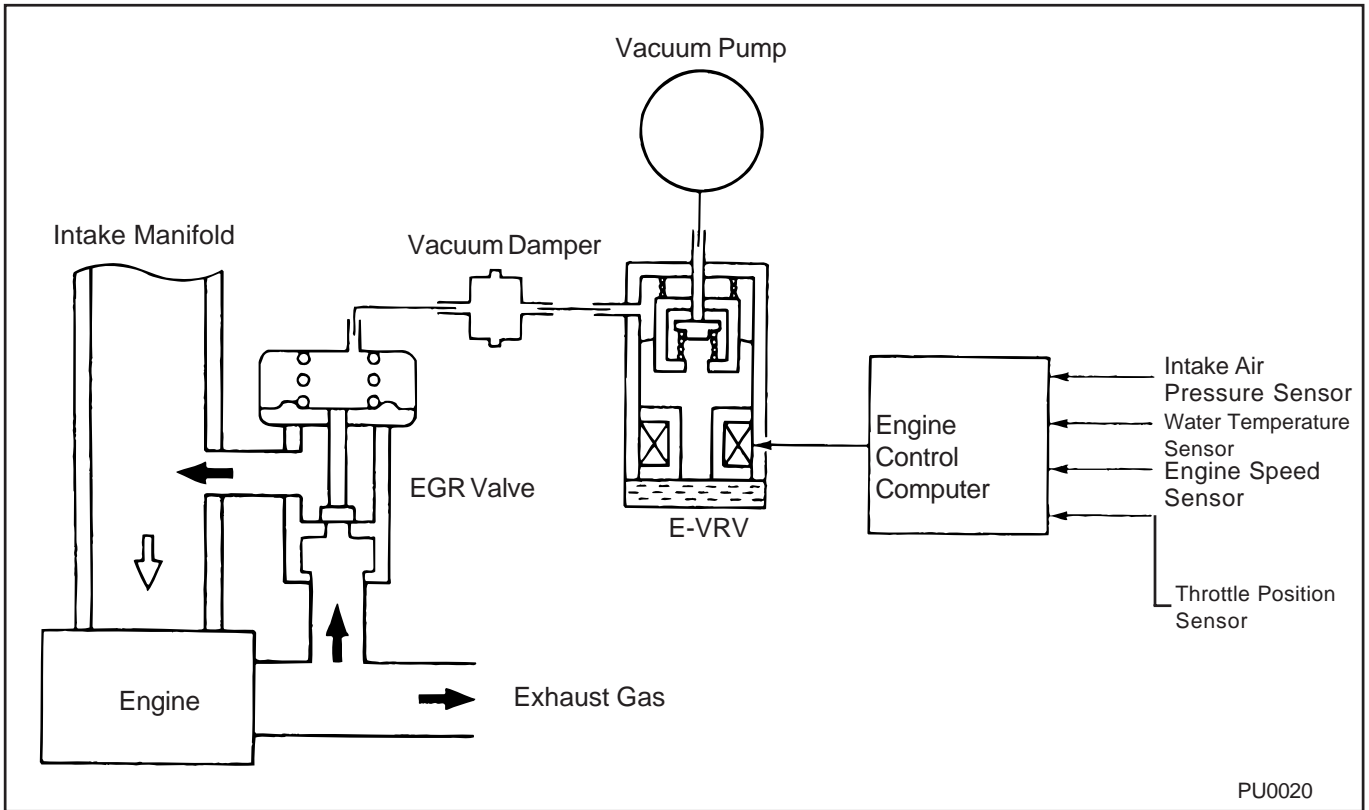

Based on the acceleration opening (throttle position sensor), engine speed, coolant water temperature, intake air pressure, and intake air temperature signals, the computer determines the volume of the recirculation of the exhaust gases and effects duty-cycle control in the operation of the vacuum control valve (E-VRV).

8-1. Construction & Operation of Components

(1) E-VRV

It is an abbreviation for the "Electric Vacuum Regulating Valve", a switching valve that is actuated electrically.

Upon receiving 500Hz duty cycle signals from the computer, the E-VRV supplies the vacuum from the vacuum pump to the diaphragm chamber.

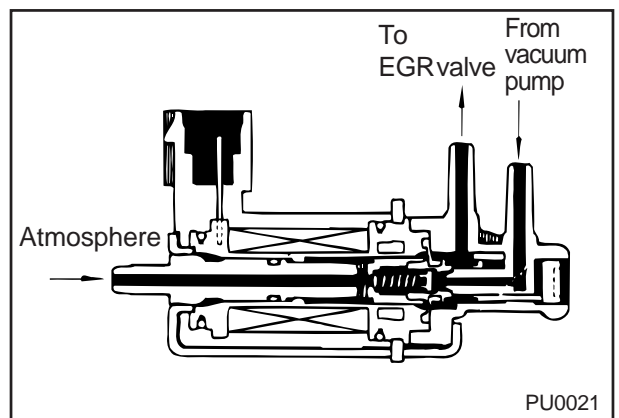

(2) EGR Valve

The EGR valve consists of a diaphragm, spring, and a nozzle. When the vacuum that is applied to the diaphragm chamber increases, the diaphragm moves upward (in the direction to compress the spring). The nozzle then opens in unison with this movement, allowing the exhaust gas from the exhaust manifold to enter into the intake manifold.

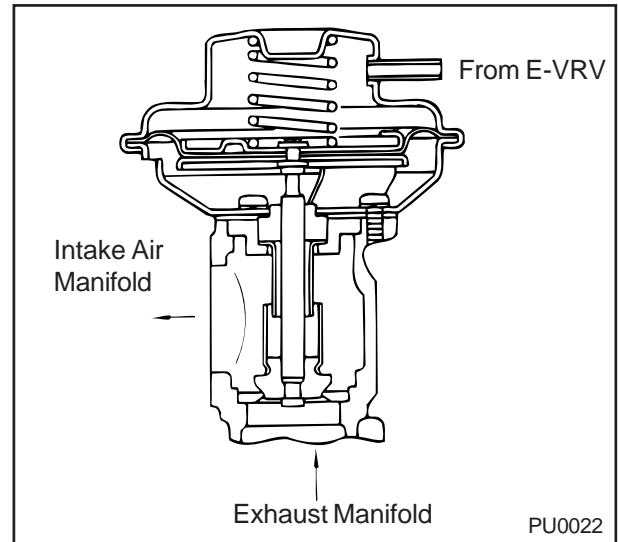

8-2. Determining the EGR Volume

(1) Other than Idle

A correction based on the coolant water temperature and the intake air pressure condition is added to the basic duty cycle value that is stored in the computer in order to determine the final duty cycle value, which controls the E-VRV. However, control will be stopped if the final duty cycle value is too small, or if the acceleration opening is too large.

(2) Idling

The final duty cycle value changes in accordance with the ON/OFF condition of the air conditioner. Control will be stopped during starting, when the engine speed is low, or the coolant water temperature is low.

8-3. EGR Correction Coefficient

A correction is made to the basic duty cycle value in accordance with the coefficient that is obtained from the water temperature sensor and intake air pressure sensor signals. (The diagram on the right gives an example of a correction coefficient.)

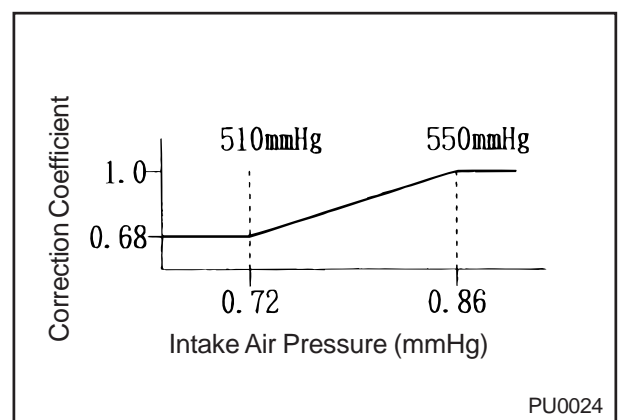
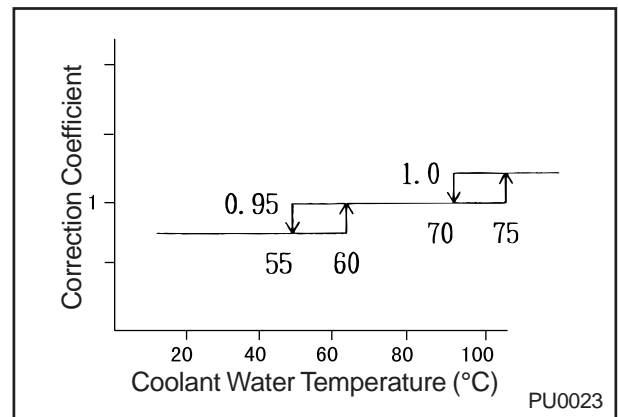

9. Glow Plug Control

This control turns ON the glow plugs to warm up the air in the combustion chamber during cold starting, while the glow plugs also serve as the source of the ignition of fuel in order to facilitate starting. Ceramic glow plugs are used as heat sources in order to simplify the system.

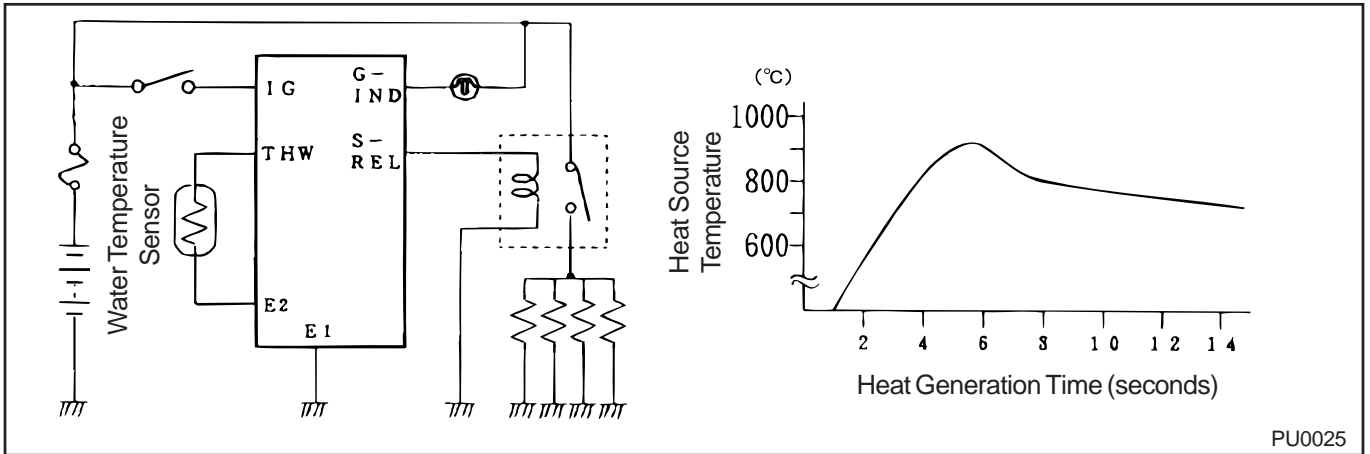

9-1. Glow Plug Indicator Illumination Time Control

When the ignition switch is turned ON, this control illuminates the glow plug indicator light only for the length of time that is determined by the coolant water temperature. The light goes out when the starter is turned ON.

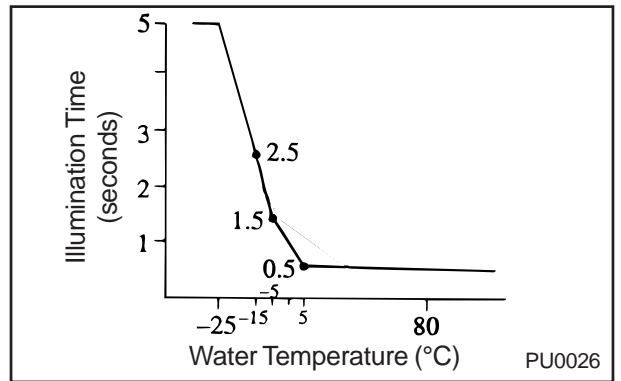

9-2. Glow Plug Relay Control

When the ignition switch is turned ON, this control energizes the glow plug relay to effect pre-heating only for the length of time that is determined by the coolant water temperature. When the starter is turned ON, the glow plug relay is energized during that time. After the engine starts and the starter is turned OFF, this control effects the after-heating control from that point.

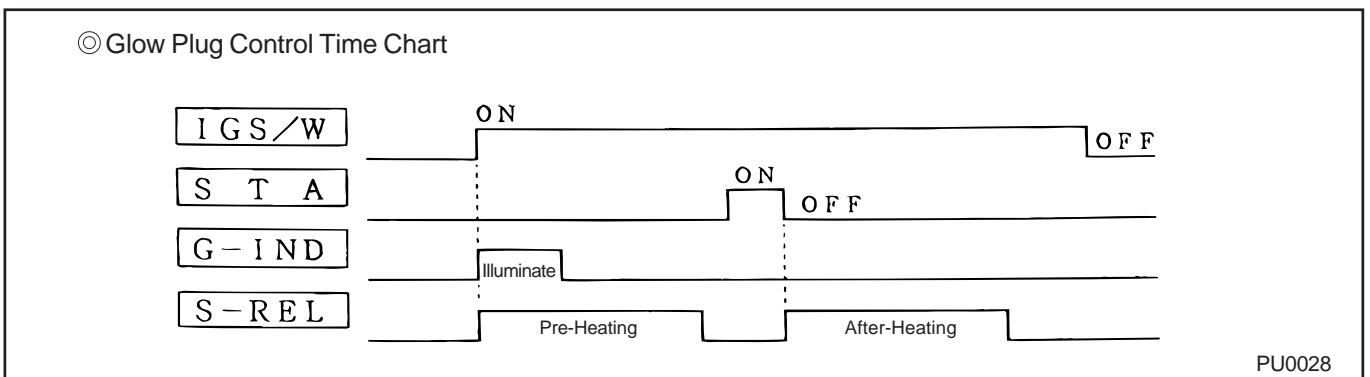
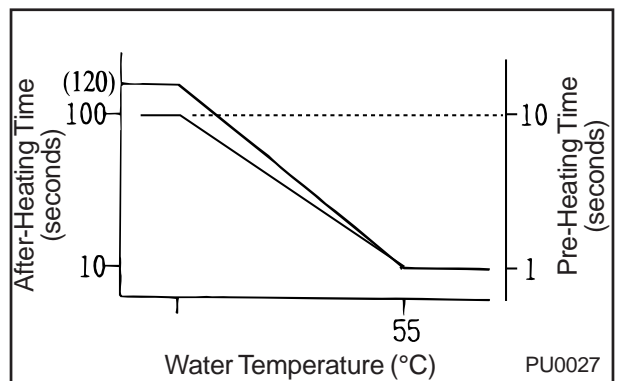

10. Other Controls (the control specifications vary by engine type)

(1) Main Relay Control

Controls the relay for the main power system. (It does not control the computer's ignition switch terminal, battery terminal, and the power to the glow plugs.)

(2) Air Conditioner Cutoff Control

With the air conditioner turned ON, if the vehicle speed and the acceleration opening become higher than the specified value, this control determines that the vehicle is being accelerated, and turns OFF the compressor for 3 seconds in order to lighten the load.

(3) Turbo Indicator Control

When the signal of the intake air pressure sensor exceeds a specified value, this control determines that the turbocharger is operating and illuminates the turbo indicator light in the meter.

(4) Engine Stall Control

When the stalling of the engine is detected, this control stops controlling the SPV, actuates the timing control valve at a fixed duty cycle ratio, and controls the sub valve to open half way.

(5) SPV Relay Control

When the engine speed is determined to have increased above a specified value, this control turns OFF the SPV relay and fully closes the sub-valve to prevent the speed from increasing further.

(6) Low Water Temperature Lockup Prohibition

When the coolant water temperature is low and the vehicle speed is below a specified value, this control outputs a lockup prohibition signal to the ECT (electronically controlled transmission) computer.

(7) Communication Control with TRC (Traction Control) Computer

When the TRC is operating, this control receives signals from the TRC computer in order to reduce the fuel injection volume and decrease the output.

(8) Overheat Control

When the coolant water temperature is higher than a specified value, and the engine speed is high, this control reduces the fuel injection volume and retards the injection timing in order to prevent the engine from overheating.

11. Diagnosis Function

This is a self-diagnosis function of the system. If an abnormal condition in a signal system of the respective control system is detected through sensors, the computer stores the malfunctioning system in its memory. Because codes are assigned to the signals for every system, the computer stores those codes in its memory. Then, it outputs the code of the system that is malfunctioning via the diagnosis connector that is provided on the vehicle. In some systems, the indicator light in the meter flashes to alert the driver. During troubleshooting, proper diagnosis can be made by reading the codes that are output by the diagnosis connector.

▼ Examples of DTCs (Diagnostic Trouble Codes)

DTC number 13: speed sensor system

DTC number 22: water temperature sensor system

▼ Examples of output signals

(1) Normal



(2) Abnormal

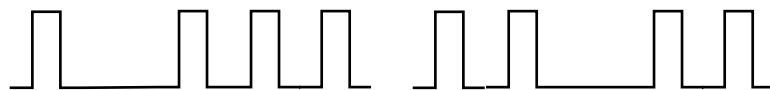

DTC number 13

DTC number 22

PR0097

12. Fail-Safe Function

If an abnormal signal is output by a sensor and if an engine malfunction could result if the system continues to use that signal to effect control, a predetermined value that is stored in the computer is used to effect control. Depending on the symptom, this function could also stop the engine.

■ Example of Fail-Safe

a. Speed Sensor Signal System

If a signal is not input from the speed sensor, this function cuts off the current that is applied to the solenoid spill valve in order to stop the injection of fuel.

b. Water Temperature Sensor Signal System

If the signal from the water temperature sensor is open or shorted, this function uses a predetermined value that is stored in the computer.

Reference: Diagnosis Codes (ex.3C-TE engine)

N.A. No Application

Code	Diagnosis Item (terminal symbol)	Diagnosis Contents (a:Condition, b:Abnormality state, c:Abnormality period)		Lamp Illumination	Memory	Main Symptom of Malfunction	Inspection Area
		Normal Mode	Check (Test) Mode				
12	Revolution signal system1 [TDC+, TDC-]	a:Engine revolution over 400 rpm b:No input of crankshaft angle signal (TDC signal)	a:Engine revolution over 400 rpm b:Two revolutions of engine resulting in crankshaft angle signal (TDC signal) other than 2	○	○	Loud knocking sound/Poor drivability	<ul style="list-style-type: none"> •Wiring harnesses and connectors (TDC signal system) •Center of crankshaft position •Engine control computer
13	Revolution signal system 2 [NE+, NE-]	a:Engine revolution over 680 rpm b:No input of NE signal c:Over 0.5 second	a:Engine revolution over 680 rpm b:One-half revolution of engine resulting in NE signal pulse count other than normal	○	○	Engine stalling / Unable to restart	<ul style="list-style-type: none"> •Wiring harnesses and connectors (NE signal system) •Diesel revolution sensor •Engine control computer
		a:During cranking b:No input of NE signal c:Over 2 seconds					
14	Timing advance control system [TCV]	a:After engine is warmed up, during driving b:Actual control value deviates from target timing advance value. c:Over 20 seconds	—	○	○	Loud knocking sound/Poor drivability	<ul style="list-style-type: none"> •Wiring harnesses and connectors (TCV signal system) •Timing control valve •Clogged fuel filter •Fuel (frozen, air intermixed) •Injection pump •Engine control computer
15	Throttle control system [PA, E1]	a:Vehicle speed over 5km/h b:After engine is warmed up, actual throttle opening deviates from target throttle opening. c:Over 2 seconds	—	○	○	Poor drivability	<ul style="list-style-type: none"> •Wiring harnesses and connectors (throttle control system) •Throttle opening sensor •Engine control computer
17 89	Internal IC system	a:Battery voltage normal b:Computer internal IC abnormal	—	○	○	—	<ul style="list-style-type: none"> •Engine control computer
18	Spill-valve system [SPV+, SPV-]	a:Engine revolution over 500 rpm b:Spill-valve shorted internally	—	○	○	Engine stalling	<ul style="list-style-type: none"> •Wiring harnesses and connectors (spill-valve system) •Spill-valve •Engine control computer
19	Acceleration sensor system [VA, VAS, E2C]	b:Accelerator sensor short or open circuit c:Over 0.05 seconds	b:Acceleration sensor short or open circuit	○	○	Poor drivability	<ul style="list-style-type: none"> •Wiring harnesses and connectors (acceleration sensor system) •Acceleration sensor •Engine control computer
19	Acceleration sensor system (idle switch) [IDL, E2C]	b:Idle switch short or open circuit. c:Over 0.05 second	—	○	○	Poor drivability	<ul style="list-style-type: none"> •Wiring harnesses and connectors (acceleration sensor system) •Acceleration sensor •Engine control computer
		b:Large deviation between signals from two accelerator sensors. c:Over 0.05 second	—	○	○		
19	Acceleration sensor system (accelerator full-open switch) [PDL]	a:Accelerator pedal fully open b:Over 5 second c:Accelerator full-open switch open circuit	—	○	○	Poor drivability	<ul style="list-style-type: none"> •Wiring harnesses and connectors (accelerator full-open switch system) •Acceleration full-open switch •Engine control computer

Code	Diagnosis Item (terminal symbol)	Diagnosis Contents (a:Condition, b:Abnormality state, c:Abnormality period)		Lamp Illumination	Memory	Main Symptom of Malfunction	Inspection Area
		Normal Mode	Check (Test) Mode				
19	Acceleration sensor system (accelerator full-open switch) [PDL]	a:Accelerator pedal fully open b:Accelerator full-open switch open circuit	—	○	○	Poor drivability	<ul style="list-style-type: none"> Wiring harnesses and connectors (accelerator full-open switch system) Acceleration full-open switch Engine control computer
22	Water temperature signal system [THW, E2]	b:Water temperature sensor circuit short or open circuit c:Less than 0.5 second	b:Water temperature sensor circuit short or open circuit c:Less than 1 second	○	○	Poor cold starting performance /Poor drivability	<ul style="list-style-type: none"> Wiring harnesses and connectors (water temperature sensor system) Water temperature sensor Engine control computer
24	Intake air temperature sensor signal system [THA, E2]	b:Intake air temperature sensor circuit short or open circuit c:Over 0.5 second	b:Intake air temperature sensor circuit short or open circuit c:less than 1 second	N.A.	○	Poor drivability	<ul style="list-style-type: none"> Wiring harnesses and connectors (intake air temperature sensor system) Intake air temperature sensor Engine control computer
32	Correction system [DATA, CLK, E2]	b:Correction circuit short or open circuit	a:Correction circuit short or open circuit c:Less than 1 second	N.A.	○	Poor drivability	<ul style="list-style-type: none"> Wiring harnesses and connectors (correction system) Correction unit Engine control computer
33	Throttle control system [S/TH, E1]	a:Battery voltage normal b:Idle stopper VSV circuit short or open circuit c:Over 0.5 second	—	○	○	Vibration when stopping engine	<ul style="list-style-type: none"> Wiring harnesses and connectors (throttle control system) Throttle position sensor Piping Idle stopper VSV
35	Turbo pressure sensor signal system [PIM, VC, E2]	a:Over engine revolution 2400 rpm, accelerator opening more than half open b:Intake manifold pressure abnormally low c:Over 2 seconds	a:Over engine revolution 2400 rpm, accelerator opening more than half open b:Intake manifold pressure abnormally low	○	○	—	<ul style="list-style-type: none"> Wiring harnesses and connectors (turbo pressure sensor system) Turbo pressure sensor Turbocharger Actuator Engine control computer
		b:Intake manifold pressure abnormally high c:Over 2 seconds	b:Intake manifold pressure abnormally high				
39	Fuel temperature sensor signal system [THF, E2]	b:Fuel temperature sensor circuit short or open circuit c:Over 0.5 second	b:Fuel temperature sensor circuit short or open circuit c:Less than 1 second	○	○	Poor drivability	<ul style="list-style-type: none"> Wiring harnesses and connectors (fuel temperature sensor system) Fuel temperature sensor Engine control computer
42	Vehicle speed sensor signal system [SP1]	a:After engine is warmed up, driving at engine revolution between 2000 to 4000 rpm b:No input of speed sensor signal c:over 8 seconds	—	○	○	—	<ul style="list-style-type: none"> Wiring harnesses and connectors (speed sensor signal system) Speed sensor Engine control computer
47	Throttle position sensor system [VLU, E2]	b:Throttle position sensor circuit short or open circuit c:Over 0.5 second	Throttle position sensor circuit short or open circuit	○	○	Poor drivability	<ul style="list-style-type: none"> Wiring harnesses and connectors (throttle position sensor system) Throttle position sensor Engine control computer

Reference: Block Diagram (ex.3C-TE engine)

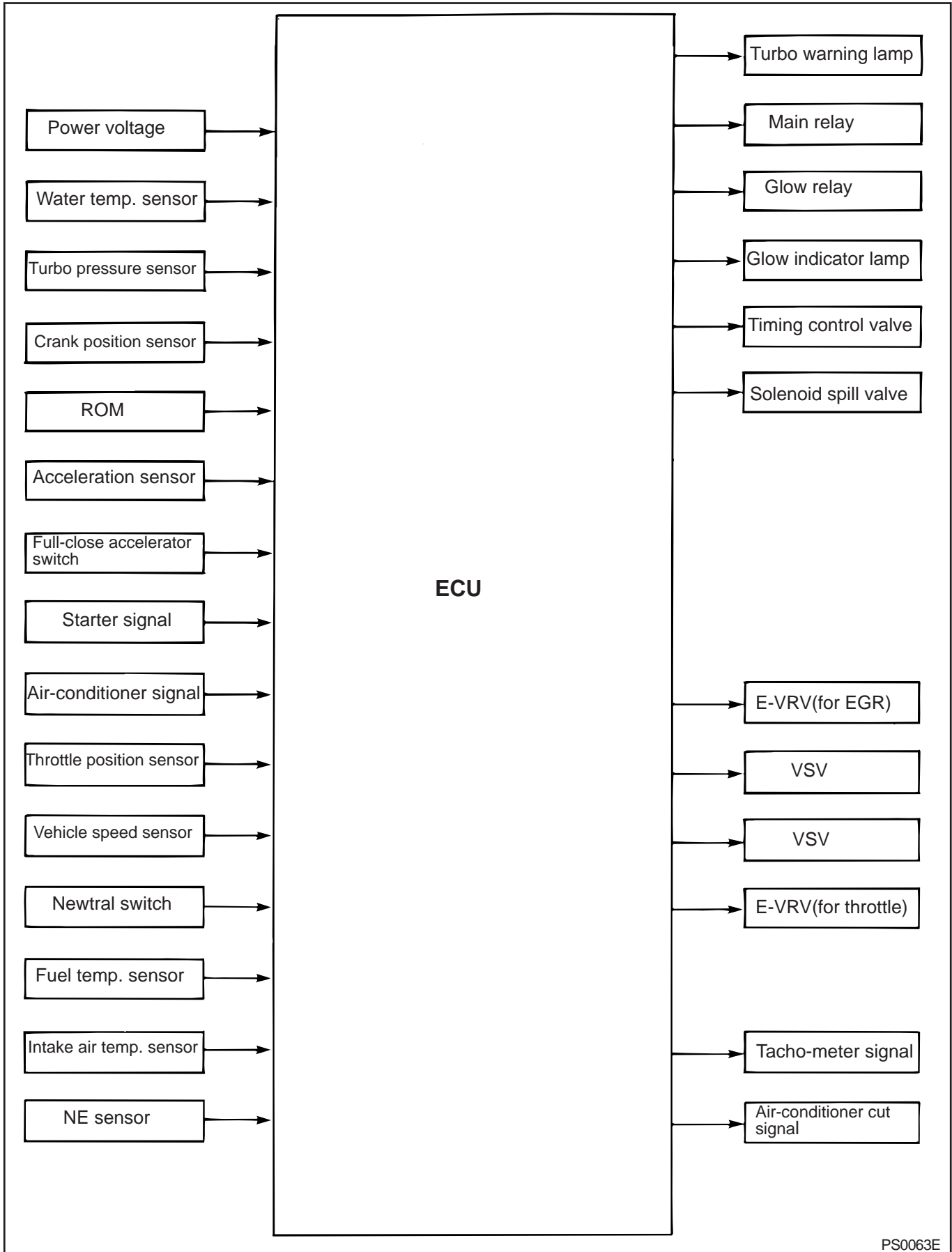

PS0063E

Reference: Connecting Diagram

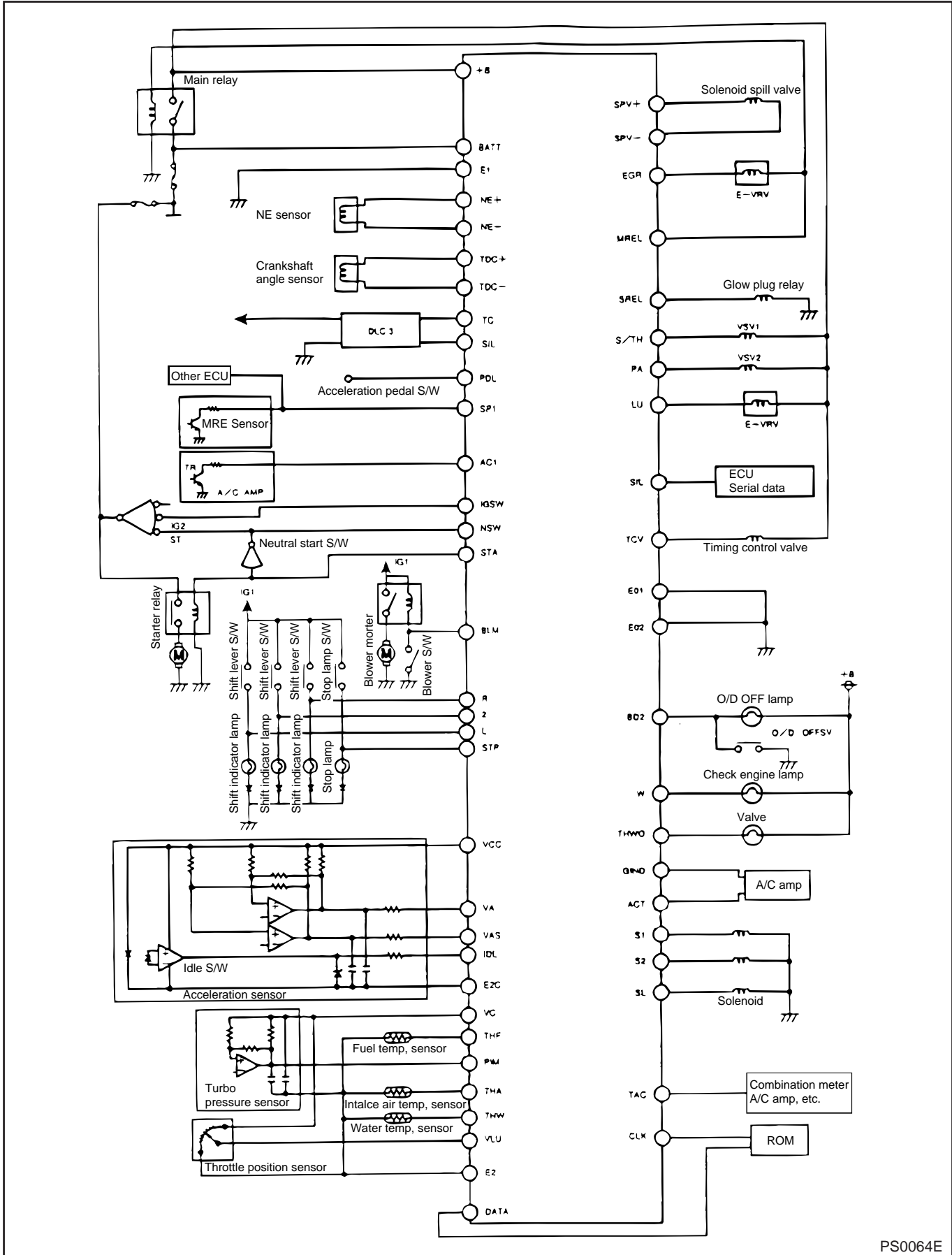

PS0064E

